

KURLAR

DALGIÇ POMPA SAN.TİC.LTD.ŞTİ.



KURLAR DALGIÇ POMPA

1990 yılında kurulan KURLAR DALGIÇ POMPA bugüne kadar derin kuyu dalgıç pompa sorunlarına çözüm üretip ürettiği bu çözümleri doğru bir şekilde uygulamıştır.

Bununla birlikte yenilikleri yakından takip eden ve kalitesini her geçen gün arttıran firmamız Ar-Ge çalışmalarınada büyük önem göstermektedir.

Üretimine halen İstanbul'da devam eden KURLAR DALGIÇ POMPA bugün üretimini sadece 6"-8" ve 10" Paslanmaz Çelik Dalgıç Pompa üzerine yoğunlaştırmıştır. Farklı 9 adet seriye sahip olan firmamız yaklaşık 320 çeşit modelle hizmet vermektedir.

Firmamız imalatını, 2000 m2 kapalı alanda, yeterli tezgah donanımı ve uzman kadrosu ile sürdürmektedir. Ürün kalitemiz ISO 9001:2008 ve CE sertifikalarıyla belgelendirilmiştir.Kurlar Dalgıç Pompa Kalite Yönetim Sistemi müşteri memnuniyetine odaklı, sistematik bir yaklaşımla iş ortaklarımızın vazgeçilmez bir çözüm ortağı olmayı hedefler.

Türkiye'de büyük bir Pazar payına sahip olan firmamız Yurtdışında hızla gelişen ihracatıyla ciddi bir pazar payı elde etmektedir.

Hedefimiz "Dalgıç Pompa" denilince ilk akla gelen , öncü ve lider bir firma olmaktır.

KURLAR POMPA was established in 1990 and we bring successfully solutions for submersible pumps. Additionally we are observe news and advance our quality day by day and concern to research and development.

The production takes place in İstanbul and intensify at this time 6"-8" and 10" stainless steel pumps. We are owning different series of 9 pumps and work for 320 different species.

Our company works with professionals on a closed area of 2000 m2 with a wide equipment.

Our product quality is certificated with ISO 9001:2008 and CE. Kurlar DALGIC POMPA is focussed of quality management systems and customer satisfaction and achieves to be an indispensable business partner with a systematic approach.

Kurlar Dalgic Pompa is sharing a big part at the turkish market and with the fast developing export we will take part in foreign markets presently

Our aim is it to be the only name for submersible pumps which comes into consideration

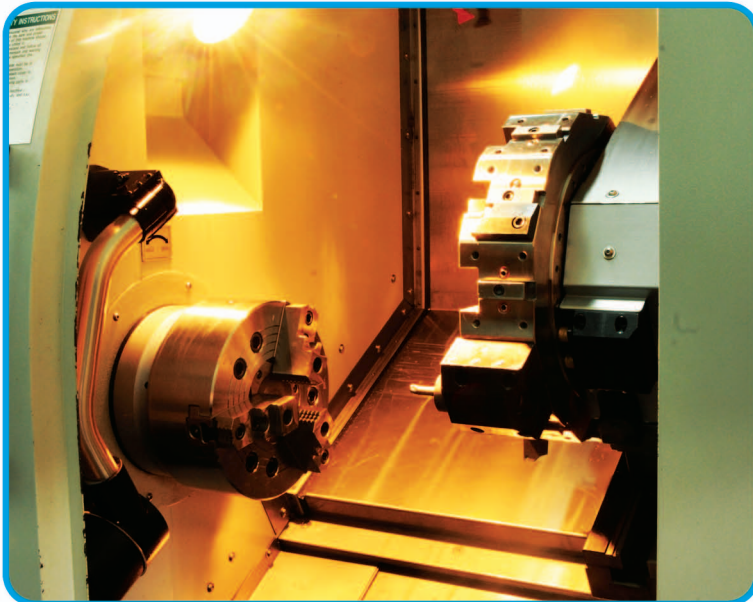
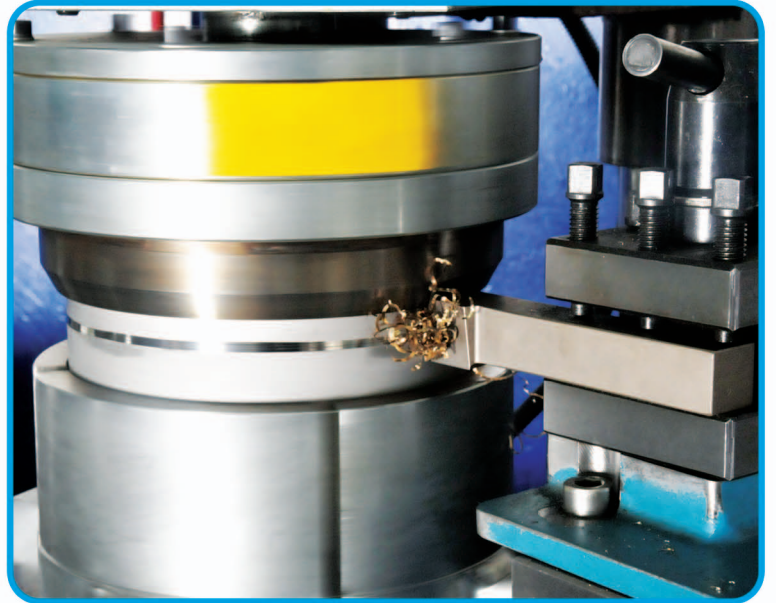
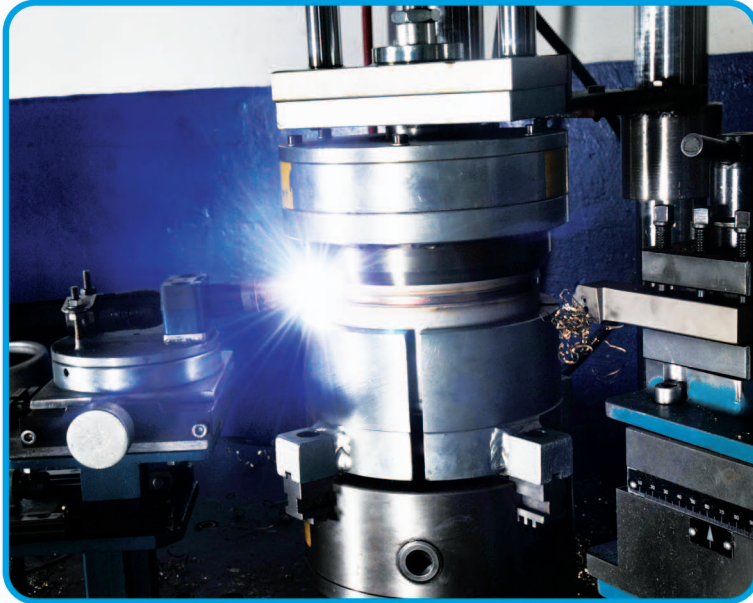

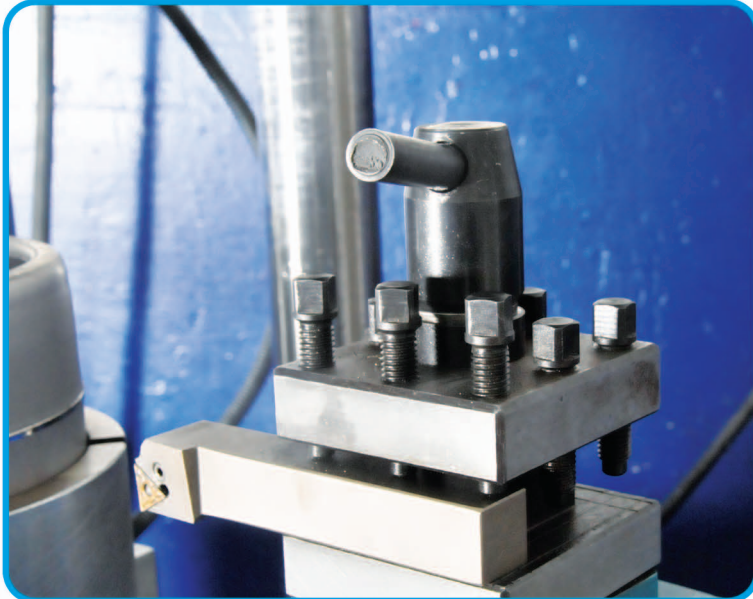
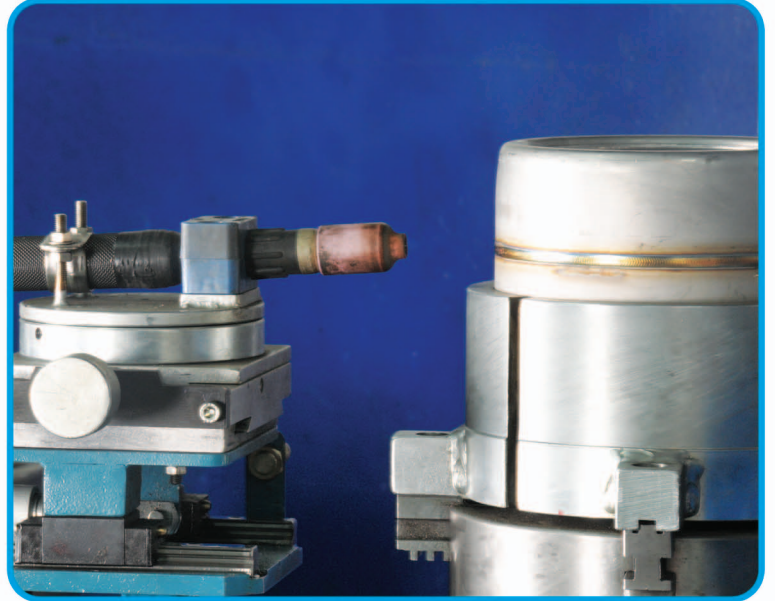
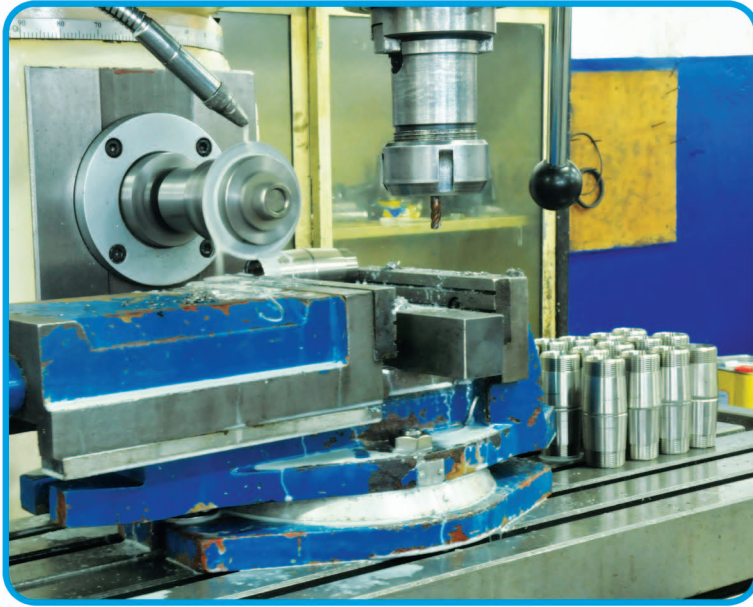

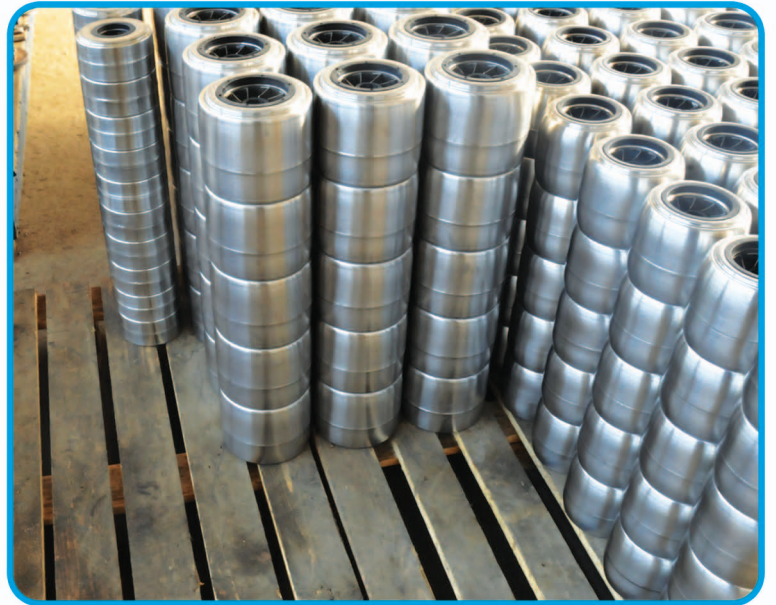
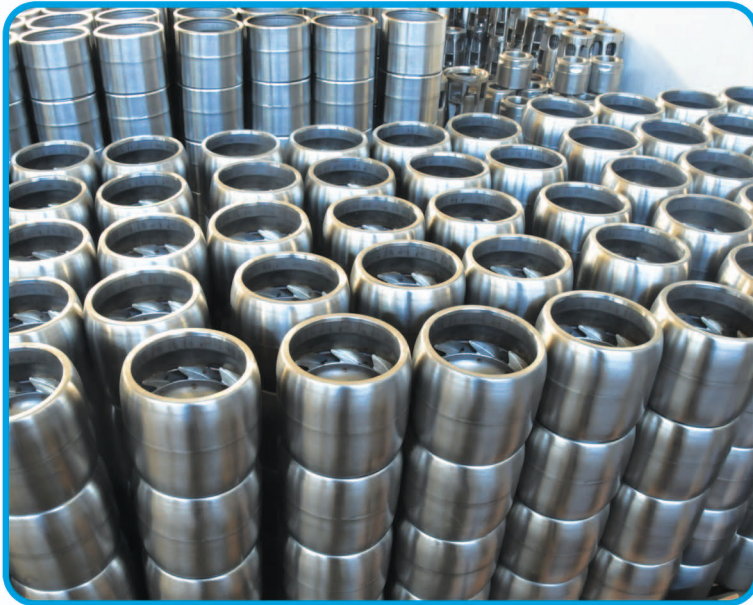
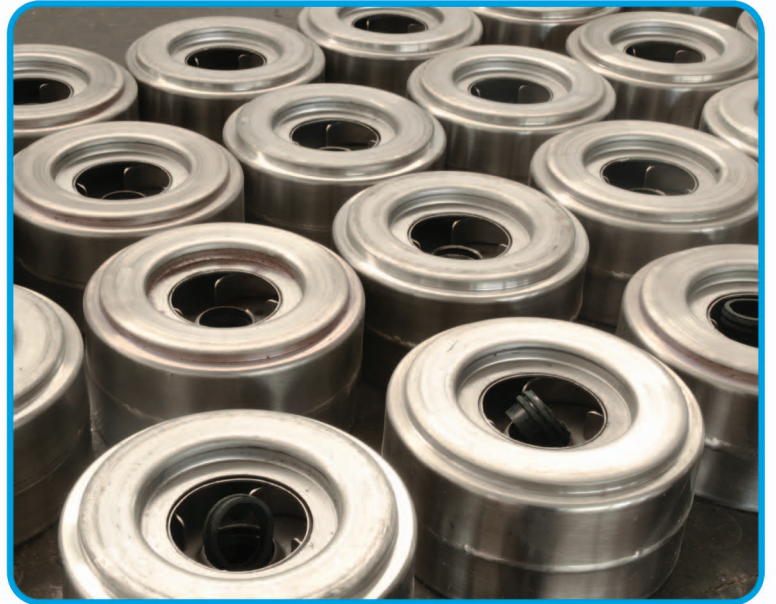



POMPA DEGERLERI / PUMP VALUES													
KADEME SAYISI	Motor		Pompa Çapı Pump Diameter	Motor Çapı	Çıkış Çapı Exit Diameter	Pompa / Pump		Motor					
	KW	HP				Uzunluk Length	Ağırlık Weight	Uzunluk Length	Ağırlık Weight				
	(mm)	(kg)	(mm)	(kg)	(mm)	(kg)	(mm)	(kg)					
KP-1809	9	0.55	0.75	98	95	1 1/4"	344	3.1	328	8			
KP-1812	12	0.75	1				407	3.6	358	9.2			
KP-1815	15	1.1	1.5				470	4.2	388	10.5			
KP-1818	18	1.1	1.5				533	4.8	388	10.5			
KP-1822	22	1.5	2				617	5.5	428	12			
KP-1825	25	1.5	2				680	6.1	428	12			
KP-1829	29	2.2	3				764	6.9	509	14.8			
KP-1833	33	2.2	3				848	7.6	509	14.8			
KP-1839	39	3	4				974	9	529	16.3			
KP-1845	45	3	4				1.145	10.4	529	16.3			
KP-1852	52	4	5.5				1.292	13.4	609	20.1			
KP-1860	60	4	5.5				1.460	16.8	609	20.1			
KP-2506	6	0.55	0.75				98	95	1 1/2"	282	2.7	328	8
KP-2508	8	0.75	1							324	3.1	358	9.2
KP-2512	12	1.1	1.5	408	3.9	388				10.5			
KP-2517	17	1.5	2	513	4.9	428				12			
KP-2521	21	2.2	3	597	5.6	509				14.8			
KP-2525	25	2.2	3	681	6.3	509				14.8			
KP-2533	33	3	4	849	7.9	529				16.3			
KP-2538	38	4	5.5	954	9.3	609				20.1			
KP-2544	44	4	5.5	1.080	10.6	609				20.1			
KP-2552	52	5.5	7.5	1.248	13.6	719				25.7			
KP-2560	60	5.5	7.5	1.416	17	719				25.7			
KP-4005	5	0.75	1	98	95	2"				409	4.3	358	9.2
KP-4007	7	1.1	1.5							493	5.2	388	10.5
KP-4010	10	1.5	2							619	6.7	428	12
KP-4012	12	2.2	3				703	7.7	509	14.8			
KP-4015	15	2.2	3				829	9.2	509	14.8			
KP-4018	18	3	4				955	10.7	529	16.3			
KP-4021	21	4	5.5				1.081	12.1	609	20.1			
KP-4025	25	4	5.5				1.249	14	609	20.1			
KP-4030	30	5.5	7.5				1.459	16.5	719	25.7			
KP-4037	37	5.5	7.5				1.753	20	719	25.7			
KP-4044	44	7.5	10				2.047	23.5	859	32.6			
KP-7505	5	1.5	2				98	95	2"	510	4.7	428	12
KP-7507	7	2.2	3							640	5.7	509	14.8
KP-7510	10	3	4							835	7.2	529	16.3
KP-7513	13	4	5.5	1.030	8.7	609				20.1			
KP-7518	18	5.5	7.5	1.355	11.2	719				25.7			
KP-7525	25	7.5	10	1.810	14.7	859				32.6			

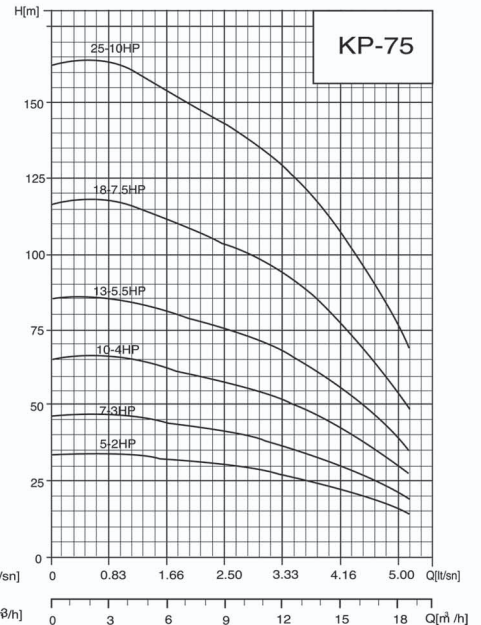
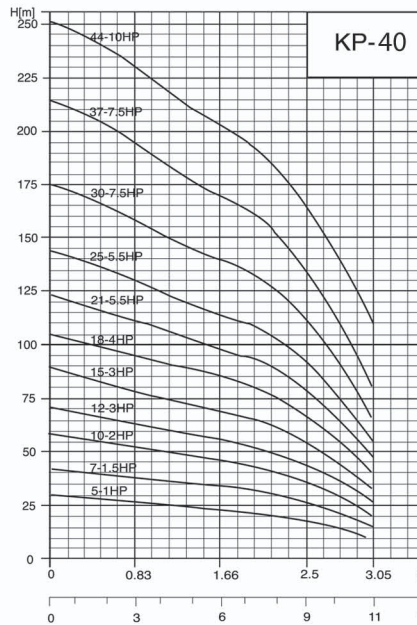
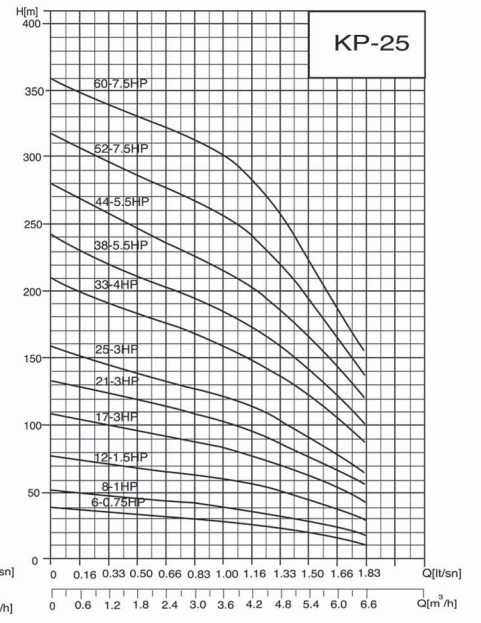
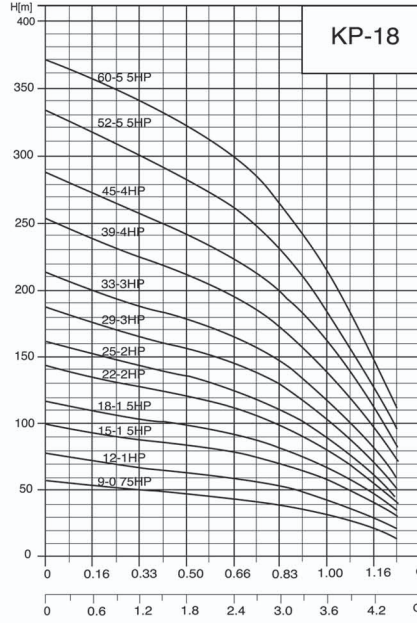

KP 18 SERİSİ PERFORMANS TABLOSU VE TEKNİK ÖZELLİKLERİ / KP 18 SERIE AND TECHNICAL FEATURES OF THE PERFORMANCE TABLES

TIP / TYPE	KADEME SAYISI STAGE NUMBER	MOTOR (HP)	[t/sn m3/h	0,28	0,42	0,56	0,69	0,83	0,97	1,11	1,25	EXIT ÇIKIŞ Inch"
				1	1,5	2	2,5	3	3,5	4	4,5	
KP-1809	9	0,75	HM (Mss)	55	52	50	45	41	34	30	23	1 1/4"
KP-1812	12	1		70	69	64	60	53	45	40	31	1 1/4"
KP-1815	15	1,5		88	83	80	75	66	57	50	38	1 1/4"
KP-1818	18	1,5		105	100	96	90	80	68	60	46	1 1/4"
KP-1822	22	2		128	122	117	110	97	83	73	52	1 1/4"
KP-1825	25	2		146	138	133	125	110	94	83	59	1 1/4"
KP-1829	29	3		169	160	155	145	128	110	97	69	1 1/4"
KP-1833	33	3		193	183	176	165	146	125	110	78	1 1/4"
KP-1839	39	4		228	216	208	195	172	147	130	92	1 1/4"
KP-1845	45	4		263	249	240	225	199	170	150	106	1 1/4"
KP-1852	52	5,5		303	288	277	260	230	196	173	123	1 1/4"
KP-1860	60	5,5		350	332	320	300	265	227	200	142	1 1/4"

KP 25 SERİSİ PERFORMANS TABLOSU VE TEKNİK ÖZELLİKLERİ / KP 25 SERIE AND TECHNICAL FEATURES OF THE PERFORMANCE TABLES

TIP / TYPE	KADEME SAYISI STAGE NUMBER	MOTOR (HP)	[t/sn m3/h	0,56	0,83	0,97	1,11	1,25	1,39	1,53	1,67	EXIT ÇIKIŞ Inch"
				2	3	3,5	4	4,5	5	5,5	6	
KP-2506	6	0,75	HM (Mss)	34	32	30	28	26	24	21	18	1 1/2"
KP-2508	8	1		44	41	38	35	34	32	28	24	1 1/2"
KP-2512	12	1,5		66	63	60	56	51	48	42	36	1 1/2"
KP-2517	17	2		93	86	80	78	71	66	58	51	1 1/2"
KP-2521	21	3		114	105	100	90	85	80	71	63	1 1/2"
KP-2525	25	3		138	130	121	112	105	97	85	75	1 1/2"
KP-2533	33	4		180	170	160	150	139	128	114	99	1 1/2"
KP-2538	38	5,5		208	195	183	172	162	150	131	113	1 1/2"
KP-2544	44	5,5		241	225	210	195	185	170	153	132	1 1/2"
KP-2552	52	7,5		282	266	250	232	215	198	178	157	1 1/2"
KP-2560	60	7,5		325	307	288	268	248	228	205	181	1 1/2"

KP 40 SERİSİ PERFORMANS TABLOSU VE TEKNİK ÖZELLİKLERİ / KP 40 SERIE AND TECHNICAL FEATURES OF THE PERFORMANCE TABLES

TIP / TYPE	KADEME SAYISI STAGE NUMBER	MOTOR (HP)	[t/sn m3/h	0,83	1,39	1,67	1,94	2,22	2,50	2,78	3,06	EXIT ÇIKIŞ Inch"
				3	5	6	7	8	9	10	11	
KP-4005	5	1	HM (Mss)	27	25	23	22	20	18	14	12	2"
KP-4007	7	1,5		37	35	32	30	27	24	20	17	2"
KP-4010	10	2		53	49	46	44	39	34	30	25	2"
KP-4012	12	3		64	60	57	54	49	45	40	34	2"
KP-4015	15	3		79	73	70	66	60	53	47	40	2"
KP-4018	18	4		95	88	84	80	72	65	55	48	2"
KP-4021	21	5,5		111	104	100	93	83	72	64	58	2"
KP-4025	25	5,5		132	124	117	110	94	83	74	67	2"
KP-4030	30	7,5		158	148	140	131	118	95	85	77	2"
KP-4037	37	7,5		195	179	167	160	141	118	100	90	2"
KP-4044	44	10		232	213	199	188	168	140	118	108	2"
KP-4044	50	10		255	232	222	213	200	175	150	114	2"

KP 75 SERİSİ PERFORMANS TABLOSU VE TEKNİK ÖZELLİKLERİ / KP 75 SERIE AND TECHNICAL FEATURES OF THE PERFORMANCE TABLES

TIP / TYPE	KADEME SAYISI STAGE NUMBER	MOTOR (HP)	[t/sn m3/h	1,67	2,22	2,78	3,33	3,89	4,17	4,44	5	EXIT ÇIKIŞ Inch"
				6	8	10	12	14	15	16	18	
KP-7505	5	2	HM (Mss)	31	29	27	25	23	21	18	14	2"
KP-7507	7	3		44	41	38	35	33	30	25	20	2"
KP-7510	10	4		62	59	55	51	46	42	35	28	2"
KP-7513	13	5,5		81	77	72	67	61	55	46	37	2"
KP-7518	18	7,5		113	107	100	93	85	77	65	51	2"
KP-7525	25	10		157	148	139	130	120	107	90	71	2"

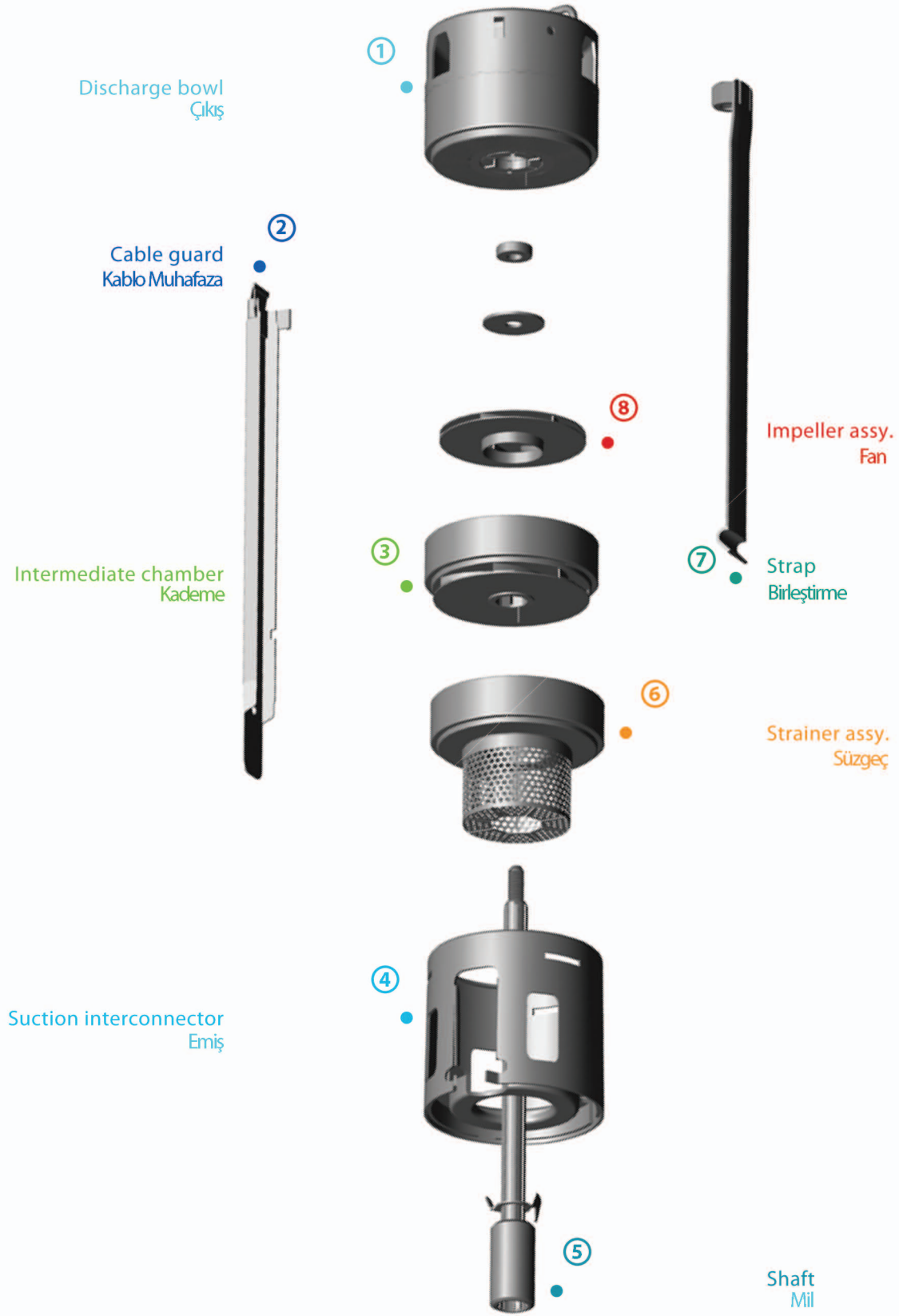

POMPA TIPI 6" PUMP TYPE 6"	MOTOR			lt/sec m3/h	DEBi / FLOW					EXIT ÇIKIŞ Inch"
	TIPI/TYPE	KW	HP		0.0	0.8	1.6	2.5	3.3	
					0	3	6	9	12	
KP-610-01	4"	0,37	0,75	H(m)	11	9	10	9	5	2"
KP-610-02	4"	0,75	1		22	21	20	18	12	2"
KP-610-03	4"	1.1	1.5		35	32	31	28	19	2"
KP-610-04	4"	1.5	2		47	45	40	38	25	2"
KP-610-05	4"	2.2	3		58	55	51	47	30	2"
KP-610-06	4"	2.2	3		69	66	62	55	38	2"
KP-610-07	4"	3	4		80	78	72	62	42	2"
KP-610-08	4"	3	4		92	90	85	72	50	2"
KP-610-09	4"	4	5.5		105	101	97	82	55	2"
KP-610-10	4"	4	5.5		116	111	107	90	60	2"
KP-610-11	4"	4	5.5		128	120	117	100	68	2"
KP-610-12	6"	5.5	7.5		137	133	126	110	71	2"
KP-610-13	6"	5.5	7.5		150	145	138	119	80	2"
KP-610-14	6"	5.5	7.5		161	157	147	128	85	2"
KP-610-15	6"	5.5	7.5		172	167	159	137	90	2"
KP-610-16	6"	7.5	10		182	180	170	145	97	2"
KP-610-17	6"	7.5	10		195	191	180	155	102	2"
KP-610-18	6"	7.5	10		208	202	190	165	110	2"
KP-610-19	6"	7.5	10		219	212	201	172	115	2"
KP-610-20	6"	7.5	10		230	225	212	181	120	2"
KP-610-21	6"	7.5	10		241	236	221	190	130	2"
KP-610-22	6"	7.5	10		252	248	232	200	133	2"
KP-610-23	6"	9.3	12.5		262	260	245	230	140	2"
KP-610-24	6"	9.3	12.5		274	270	255	220	145	2"
KP-610-25	6"	9.3	12.5		289	280	265	230	150	2"
KP-610-26	6"	9.3	12.5		298	291	277	238	158	2"
KP-610-27	6"	9.3	12.5		310	303	288	247	160	2"
KP-610-28	6"	11	15		321	313	297	258	170	2"
KP-610-29	6"	11	15		332	325	308	265	175	2"
KP-610-30	6"	11	15		344	336	317	275	180	2"
KP-610-31	6"	11	15		357	348	328	280	185	2"
KP-610-32	6"	11	15		368	360	340	290	190	2"
KP-610-33	6"	13	17.5		380	371	350	300	200	2"
KP-610-34	6"	13	17.5		390	382	361	310	207	2"
KP-610-35	6"	13	17.5		401	391	371	320	211	2"
KP-610-36	6"	13	17.5		412	402	381	330	214	2"
KP-610-37	6"	13	17.5		424	413	390	338	220	2"
KP-610-38	6"	13	17.5		435	425	402	348	225	2"
KP-610-39	6"	15	20		447	438	412	357	239	2"
KP-610-40	6"	15	20		459	447	421	365	241	2"
KP-610-41	6"	15	20		470	458	432	375	250	2"
KP-610-42	6"	15	20		481	470	442	382	255	2"
KP-610-43	6"	15	20		492	480	453	390	260	2"
KP-610-44	6"	15	20		502	490	462	400	263	2"
KP-610-45	6"	18.5	25		517	501	475	410	270	2"
KP-610-46	6"	18.5	25		529	512	482	421	275	2"
KP-610-48	6"	18.5	25		550	539	509	435	290	2"
KP-610-52	6"	18.5	25		597	581	550	470	320	2"

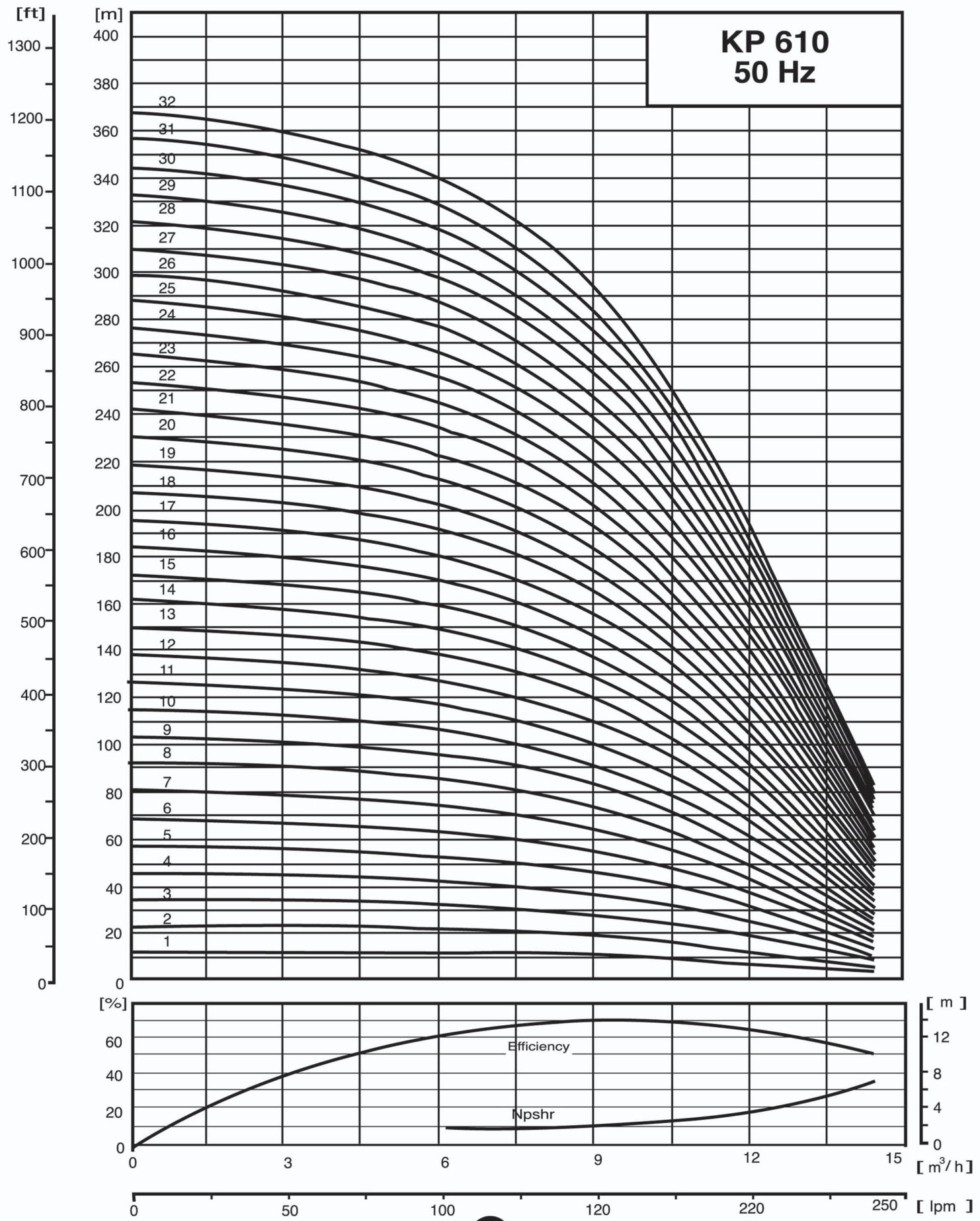

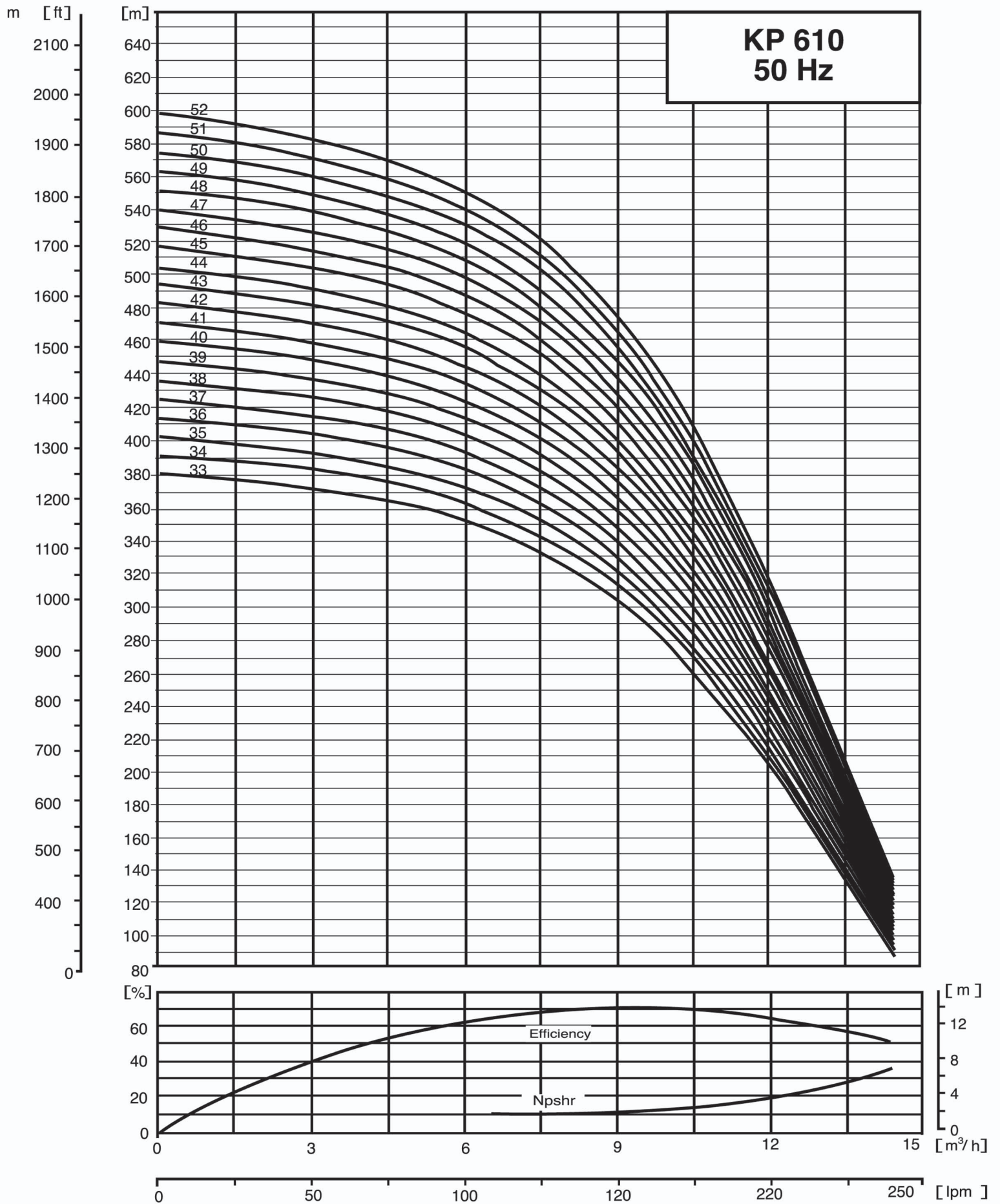

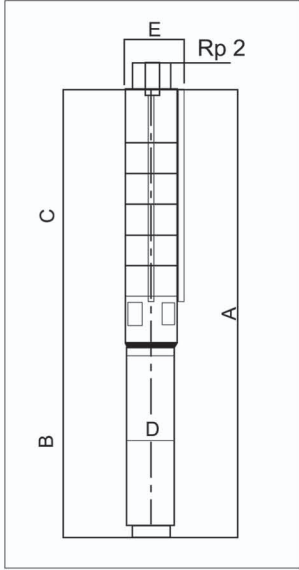

POMPA TİPİ PUMP TYPE	MOTOR		POMPA EBAT ÖLÇÜLER (mm) PUMP DIMENSIONS (mm)						NET AĞIRLIK (kg)	NET WEIGHT (kg)
	TİP / TYPE	GÜÇ (kW) POWER	C	B	A	D	E*	E**		
KP 610-1	Motor 6"	0.37	417	486	903	95	141		25	
KP 610-2	Motor 6"	0.75	472	486	958	95	141		27	
KP 610-3	Motor 6"	1.1	527	536	1063	95	141		28	
KP 610-4	Motor 6"	1.5	582	586	1168	95	141		31	
KP 610-5	Motor 6"	2.2	637	636	1273	95	141		38	
KP 610-6	Motor 6"	2.2	692	636	1328	95	141		39	
KP 610-7	Motor 6"	3.0	747	776	1523	95	141		45	
KP 610-8	Motor 6"	3.0	802	776	1578	95	141		47	
KP 610-9	Motor 6"	4.0	857	658	1515	143	152	152	68	
KP 610-10	Motor 6"	4.0	912	658	1570	143	152	152	70	
KP 610-11	Motor 6"	4.0	967	658	1625	143	152	152	71	
KP 610-12	Motor 6"	5.5	1022	698	1720	143	152	152	84	
KP 610-13	Motor 6"	5.5	1077	698	1775	143	152	152	85	
KP 610-14	Motor 6"	5.5	1132	698	1830	143	152	152	86	
KP 610-15	Motor 6"	5.5	1187	698	1885	143	152	152	87	
KP 610-16	Motor 6"	7.5	1287	748	2035	143	152	152	93	
KP 610-17	Motor 6"	7.5	1342	748	2090	143	152	152	95	
KP 610-18	Motor 6"	7.5	1397	748	2145	143	152	152	96	
KP 610-19	Motor 6"	7.5	1452	748	2200	143	152	152	97	
KP 610-20	Motor 6"	7.5	1507	748	2255	143	152	152	99	
KP 610-21	Motor 6"	7.5	1562	748	2310	143	152	152	100	
KP 610-22	Motor 6"	7.5	1617	748	2365	143	152	152	102	
KP 610-23	Motor 6"	9.2	1672	788	2460	143	152	152	108	
KP 610-24	Motor 6"	9.2	1727	788	2515	143	152	152	109	
KP 610-25	Motor 6"	9.2	1782	788	2570	143	152	152	110	
KP 610-26	Motor 6"	9.2	1837	788	2625	143	152	152	111	
KP 610-27	Motor 6"	9.2	1892	788	2680	143	152	152	112	
KP 610-28	Motor 6"	11.0	1947	866	2813	143	152	152	117	
KP 610-29	Motor 6"	11.0	2002	866	2868	143	152	152	118	
KP 610-30	Motor 6"	11.0	2057	866	2923	143	152	152	119	
KP 610-31	Motor 6"	11.0	2157	866	3023	143	152	152	121	
KP 610-32	Motor 6"	11.0	2212	866	3078	143	152	152	123	
KP 610-33	Motor 6"	13.0	2267	878	3145	143	152	152	132	
KP 610-34	Motor 6"	13.0	2322	878	3200	143	152	152	134	
KP 610-35	Motor 6"	13.0	2377	878	3255	143	152	152	135	
KP 610-36	Motor 6"	13.0	2432	878	3310	143	152	152	136	
KP 610-37	Motor 6"	13.0	2487	878	3365	143	152	152	138	
KP 610-38	Motor 6"	13.0	2542	878	3420	143	152	152	139	
KP 610-39	Motor 6"	15.0	2597	923	3520	143	152	152	142	
KP 610-40	Motor 6"	15.0	2652	923	3575	143	152	152	144	
KP 610-41	Motor 6"	15.0	2707	923	3630	143	152	152	145	
KP 610-42	Motor 6"	15.0	2762	923	3685	143	152	152	146	
KP 610-43	Motor 6"	15.0	2817	923	3740	143	152	152	148	
KP 610-44	Motor 6"	15.0	2917	923	3840	143	152	152	150	
KP 610-45	Motor 6"	18.5	2972	1013	3985	143	152	152	159	
KP 610-46	Motor 6"	18.5	3027	1013	4040	143	152	152	161	
KP 610-47	Motor 6"	18.5	3082	1013	4095	143	152	152	162	
KP 610-49	Motor 6"	18.5	3137	1013	4150	143	152	152	163	
KP 610-50	Motor 6"	18.5	3192	1013	4205	143	152	152	165	
KP 610-51	Motor 6"	18.5	3247	1013	4260	143	152	152	166	
KP 610-52	Motor 6"	18.5	3302	1013	4315	143	152	152	168	

POMPA TIPI 6" PUMP TYPE 6"	MOTOR			It/sec m3/h	DEBİ / FLOW								EXIT ÇIKIŞ inch"
	TIPI/TYPE	KW	HP		0.0	1.1	2.2	3.3	3.9	4.4	5.6		
					0	4	8	12	14	16	20		
KP-617-01	4"	0,55	0,75	H(m)	12	11	10	9	8	7	5	2 1/2"	
KP-617-02	4"	1,1	1,5		23	22	21	19	17	16	11	2 1/2"	
KP-617-03	4"	2,2	3		34	33	32	29	27	25	19	2 1/2"	
KP-617-04	4"	2,2	3		45	44	43	38	36	33	25	2 1/2"	
KP-617-05	4"	3	4		56	55	54	49	45	41	31	2 1/2"	
KP-617-06	4"	4	5,5		68	67	65	59	55	51	38	2 1/2"	
KP-617-07	4"	4	5,5		78	77	75	69	64	58	44	2 1/2"	
KP-617-08	4"	5,5	7,5		90	89	87	80	75	68	52	2 1/2"	
KP-617-09	6"	5,5	7,5		101	100	97	88	83	76	58	2 1/2"	
KP-617-10	6"	5,5	7,5		112	111	107	98	91	85	63	2 1/2"	
KP-617-11	6"	7,5	10		124	123	119	109	102	93	72	2 1/2"	
KP-617-12	6"	7,5	10		135	134	129	119	111	101	77	2 1/2"	
KP-617-13	6"	7,5	10		145	144	140	128	119	109	83	2 1/2"	
KP-617-14	6"	9,2	12,5		157	156	152	139	130	119	91	2 1/2"	
KP-617-15	6"	9,2	12,5		168	167	162	148	139	127	97	2 1/2"	
KP-617-16	6"	9,2	12,5		179	178	172	158	147	134	102	2 1/2"	
KP-617-17	6"	9,2	12,5		189	188	182	166	155	141	107	2 1/2"	
KP-617-18	6"	11	15		201	200	194	178	167	151	117	2 1/2"	
KP-617-19	6"	11	15		212	210	204	188	175	160	121	2 1/2"	
KP-617-20	6"	11	15		222	221	215	196	182	168	126	2 1/2"	
KP-617-21	6"	13	17,5		235	234	228	209	195	178	138	2 1/2"	
KP-617-22	6"	13	17,5		246	245	238	218	204	186	142	2 1/2"	
KP-617-23	6"	13	17,5		257	255	248	227	212	194	148	2 1/2"	
KP-617-24	6"	13	17,5		268	265	258	236	220	200	152	2 1/2"	
KP-617-25	6"	15	20		280	269	270	249	232	212	162	2 1/2"	
KP-617-26	6"	15	20		290	279	280	257	240	220	168	2 1/2"	
KP-617-27	6"	15	20		301	300	290	266	249	228	172	2 1/2"	
KP-617-28	6"	18,5	25		315	312	304	281	262	241	185	2 1/2"	
KP-617-29	6"	18,5	25		326	324	315	290	271	250	190	2 1/2"	
KP-617-30	6"	18,5	25		337	335	325	300	280	258	198	2 1/2"	
KP-617-31	6"	18,5	25		348	346	336	309	288	265	202	2 1/2"	
KP-617-32	6"	18,5	25		359	356	347	318	297	271	209	2 1/2"	
KP-617-33	6"	18,5	25		369	368	356	328	305	279	212	2 1/2"	
KP-617-34	6"	22	30		381	380	370	340	318	291	222	2 1/2"	
KP-617-35	6"	22	30		392	390	380	350	327	299	228	2 1/2"	
KP-617-36	6"	22	30		403	401	390	359	335	305	234	2 1/2"	
KP-617-37	6"	22	30		414	412	400	368	343	315	239	2 1/2"	
KP-617-38	6"	22	30		425	423	410	377	351	322	245	2 1/2"	
KP-617-39	6"	22	30		435	432	420	386	360	330	250	2 1/2"	
KP-617-40	6"	22	30		446	444	430	395	368	338	255	2 1/2"	
KP-617-43	6"	26	35		482	480	465	429	400	368	280	2 1/2"	
KP-617-45	6"	26	35		502	500	485	448	418	380	290	2 1/2"	
KP-617-48	6"	26	35		535	532	516	472	441	403	305	2 1/2"	
KP-617-51	6"	30	40		568	565	548	505	470	430	330	2 1/2"	
KP-617-53	6"	30	40		589	586	568	522	489	448	340	2 1/2"	
KP-617-55	6"	30	40		618	615	599	552	518	475	368	2 1/2"	
KP-617-58	6"	37	50		650	647	630	580	545	498	385	2 1/2"	
KP-617-60	6"	37	50		671	669	650	600	560	515	395	2 1/2"	

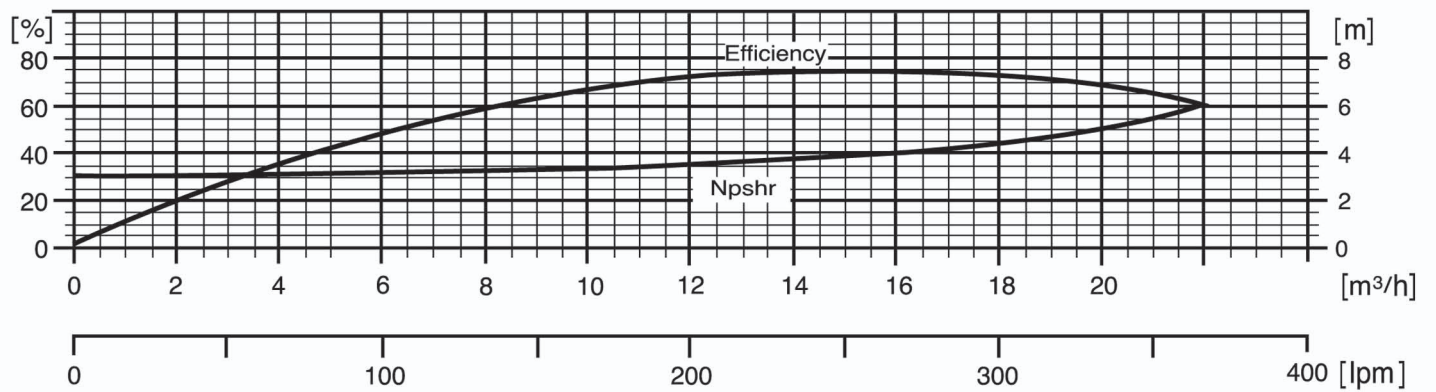
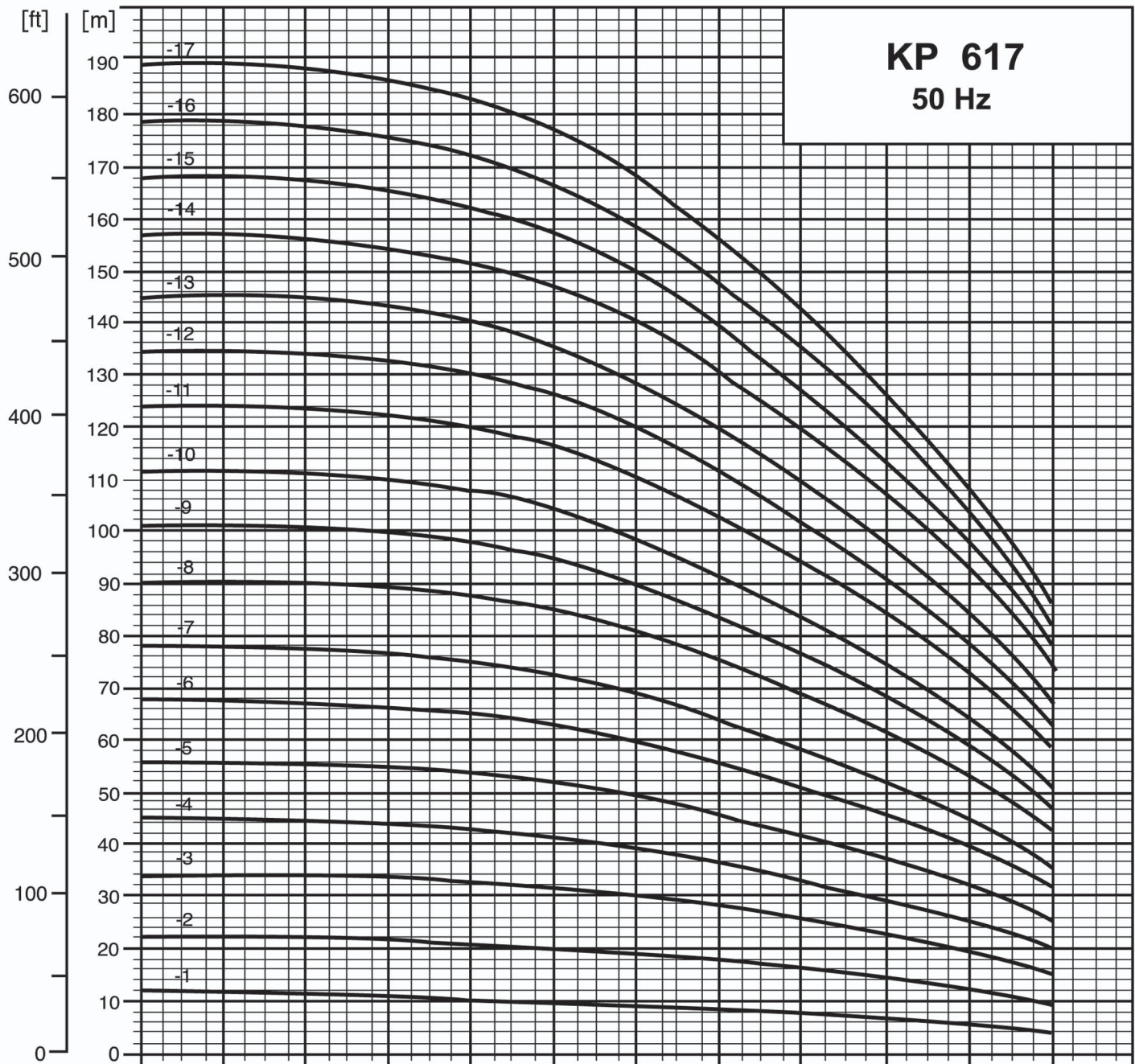

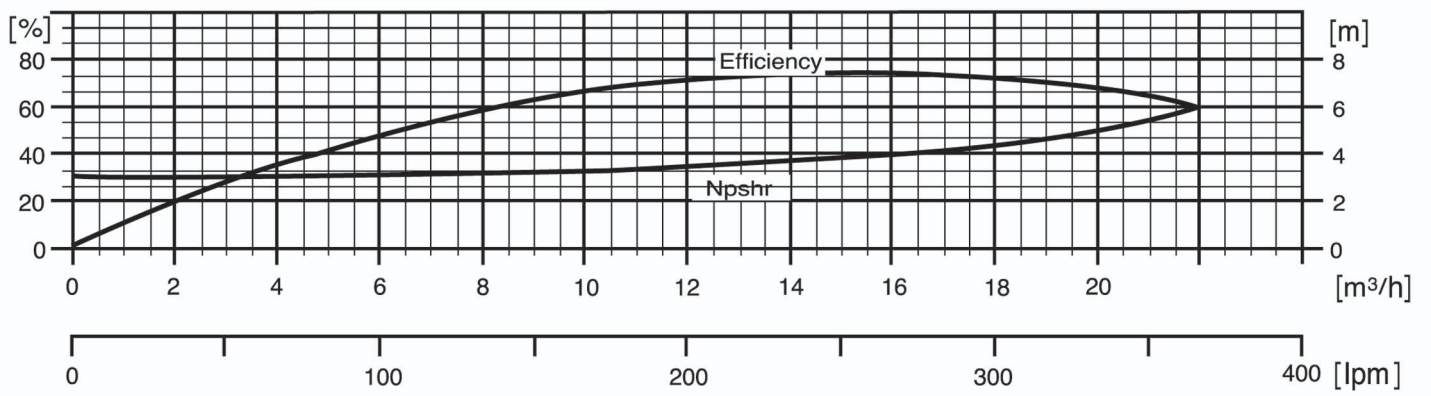
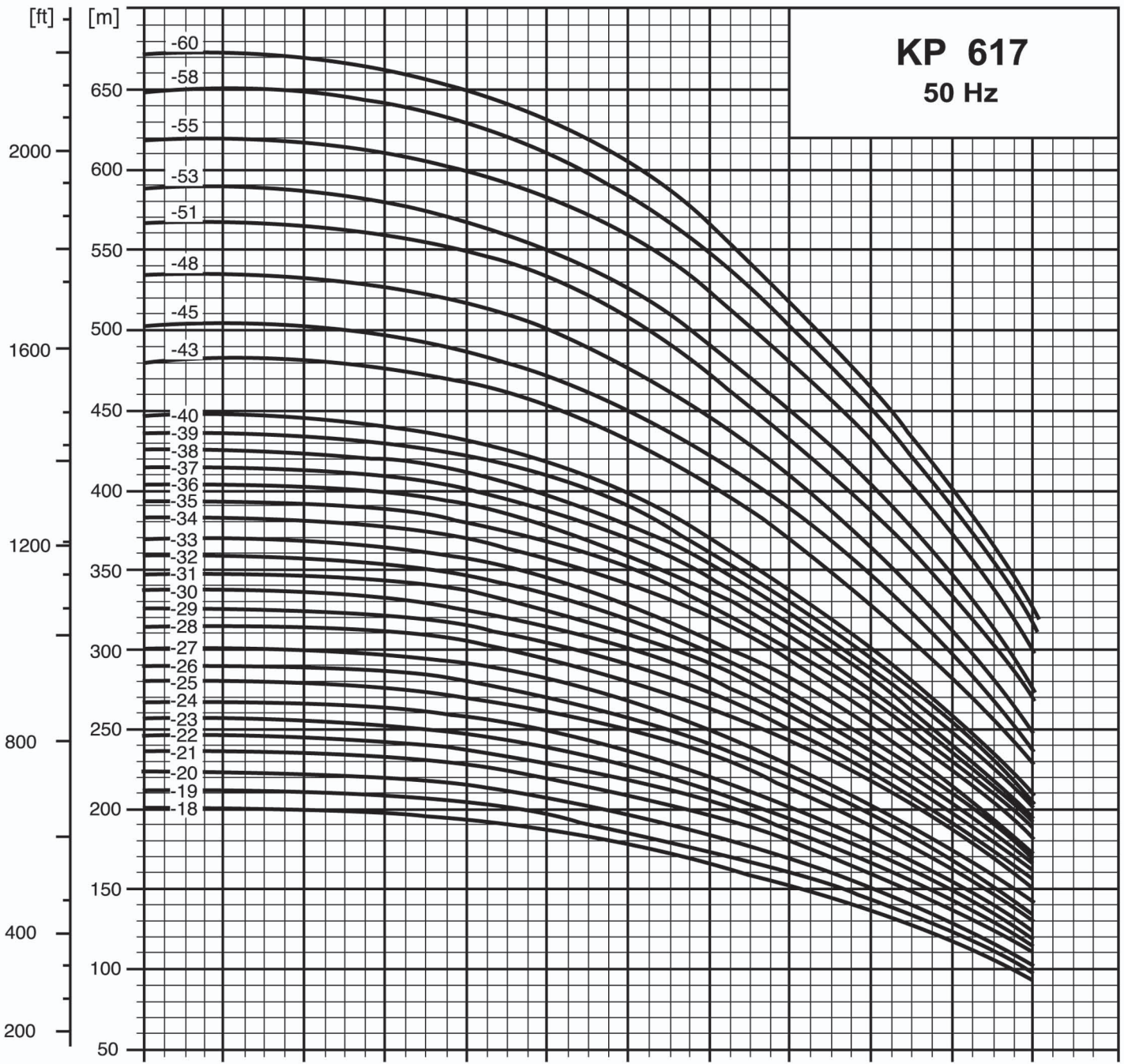

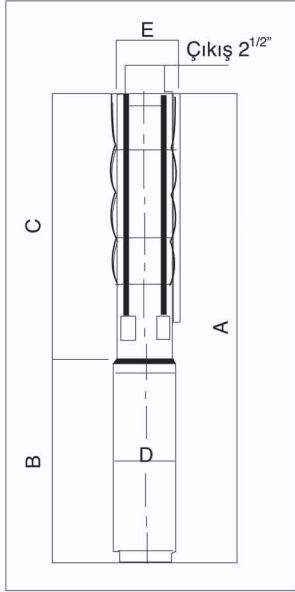

POMPA TIPI PUMP TYPE	MOTOR		POMPA EBAT ÖLÇÜLER (mm) PUMP DIMENSIONS (mm)							NET AĞIRLIK (kg)	NET WEIGHT (kg)	
	TİP TYPE	GÜÇ (kW)	C	B		A		D	E*	E**	1x230V	3x220V 3x400V
				1x230V	3x220V 3x400V	1x230V	3x220V 3x400V					
KP 617-1	MOTOR 4"	0.55	314	486		800		95	131		19	13
KP 617-2	MOTOR 4"	1.1	374	536		910		95	131		25	20
KP 617-3	MOTOR 4"	2.2	435	636	636	1071	1071	95	131		32	32
KP 617-4	MOTOR 4"	2.2	495	636	636	1131	1131	95	131		33	33
KP 617-5	MOTOR 4"	3.0	556	736	776	1292	1332	95	131		39	38
KP 617-6	MOTOR 4"	4.0	616	836	776	1452	1392	95	131		44	40
KP 617-7	MOTOR 4"	4.0	677	836	776	1513	1453	95	131		45	41
KP 617-8	MOTOR 4"	5.5	737		673		1410	95	131			42
KP 617-9	MOTOR 4"	5.5	798		698		1496	95	131			43
KP 617-10	MOTOR 4"	5.5	858		698		1556	95	131			44
KP 617-11	MOTOR 4"	7.5	919		774		1693	95	131			48
KP 617-12	MOTOR 4"	7.5	979		774		1753	95	131			49
KP 617-13	MOTOR 4"	7.5	1040		774		1814	95	131			50
KP 617-6	MOTOR 6"	4.0	632		658		1290	143	143	145		52
KP 617-7	MOTOR 6"	4.0	693		658		1351	143	143	145		53
KP 617-8	MOTOR 6"	5.5	753		698		1451	143	143	145		60
KP 617-9	MOTOR 6"	5.5	814		698		1512	143	143	145		61
KP 617-10	MOTOR 6"	5.5	874		698		1572	143	143	145		62
KP 617-11	MOTOR 6"	7.5	935		748		1683	143	143	145		70
KP 617-12	MOTOR 6"	7.5	995		748		1743	143	143	145		72
KP 617-13	MOTOR 6"	7.5	1050		748		1804	143	143	145		73
KP 617-14	MOTOR 6"	9.2	1116		788		1904	143	143	145		79
KP 617-15	MOTOR 6"	9.2	1177		788		1965	143	143	145		80
KP 617-16	MOTOR 6"	9.2	1237		788		2025	143	143	145		82
KP 617-17	MOTOR 6"	9.2	1298		788		2086	143	143	145		83
KP 617-18	MOTOR 6"	11	1358		833		2191	143	143	145		88
KP 617-19	MOTOR 6"	11	1419		833		2252	143	143	145		89
KP 617-20	MOTOR 6"	11	1479		833		2312	143	143	145		91
KP 617-21	MOTOR 6"	13	1540		878		2418	143	143	145		96
KP 617-22	MOTOR 6"	13	1600		878		2478	143	143	145		97
KP 617-23	MOTOR 6"	13	1661		878		2539	143	143	145		98
KP 617-24	MOTOR 6"	13	1721		878		2599	143	143	145		99
KP 617-25	MOTOR 6"	15	1782		923		2705	143	143	145		104
KP 617-26	MOTOR 6"	15	1842		923		2765	143	143	145		106
KP 617-27	MOTOR 6"	15	1903		923		2826	143	143	145		107
KP 617-28	MOTOR 6"	18.5	1963		1013		2976	143	143	145		119
KP 617-29	MOTOR 6"	18.5	2024		1013		3037	143	143	145		120
KP 617-30	MOTOR 6"	18.5	2084		1013		3097	143	143	145		121
KP 617-31	MOTOR 6"	18.5	2145		1013		3158	143	143	145		122
KP 617-32	MOTOR 6"	18.5	2205		1013		3218	143	143	145		123
KP 617-33	MOTOR 6"	18.5	2266		1013		3279	143	143	145		125
KP 617-34	MOTOR 6"	22	2326		1098		3424	143	143	145		134
KP 617-35	MOTOR 6"	22	2387		1098		3485	143	143	145		136
KP 617-36	MOTOR 6"	22	2447		1098		3545	143	143	145		137
KP 617-37	MOTOR 6"	22	2508		1098		3606	143	143	145		139
KP 617-38	MOTOR 6"	22	2568		1098		3666	143	143	145		140
KP 617-39	MOTOR 6"	22	2629		1098		3727	143	143	145		142
KP 617-40	MOTOR 6"	22	2689		1098		3787	143	143	145		144
KP 617-43	MOTOR 6"	26	3118		1193		4311	143	143	145		159
KP 617-45	MOTOR 6"	26	3239		1193		4432	143	143	145		162
KP 617-48	MOTOR 6"	26	3420		1193		4613	143	143	145		168
KP 617-51	MOTOR 6"	30	3602		1233		4835	143	143	145		177
KP 617-53	MOTOR 6"	30	3723		1233		4956	143	143	145		181
KP 617-51	MOTOR 6"	30	3602		934		4536	188	188	188		204
KP 617-53	MOTOR 6"	30	3723		934		4657	188	188	188		208
KP 617-55	MOTOR 6"	37	3844		1034		4878	188	188	188		222
KP 617-58	MOTOR 6"	37	4025		1034		5059	188	188	188		228
KP 617-60	MOTOR 6"	37	4146		1034		5180	188	188	188		232

POMPA TİPİ 6" PUMP TYPE 6"	MOTOR			lt/sec m3/h	DEBİ / FLOW								EXIT ÇIKIŞ Inch"
	TİPİ/TYPE	KW	HP		0.0	2.2	4.4	6.7	7.8	8.9	10.8		
KP-630-01	4"	1,1	1,5	H(m)	12	11	10	8	7	6	3	3"	
KP-630-02	4"	2,2	3		23	22	20	18	15	13	7	3"	
KP-630-03	4"	3	4		35	33	30	27	23	20	12	3"	
KP-630-04	6"	4	5,5		46	45	40	35	32	27	16	3"	
KP-630-05	6"	5,5	7,5		58	56	51	45	41	35	21	3"	
KP-630-06	6"	5,5	7,5		69	67	60	53	48	41	25	3"	
KP-630-07	6"	7,5	10		81	79	71	63	57	49	30	3"	
KP-630-08	6"	7,5	10		91	89	80	71	64	55	34	3"	
KP-630-09	6"	9,2	12,5		103	101	91	80	73	63	39	3"	
KP-630-10	6"	9,2	12,5		114	111	100	89	80	69	43	3"	
KP-630-11	6"	9,2	12,5		125	122	110	97	87	75	45	3"	
KP-630-12	6"	11	15		137	133	121	106	96	83	51	3"	
KP-630-13	6"	11	15		148	144	130	115	103	89	53	3"	
KP-630-14	6"	13	17,5		160	156	141	124	113	98	61	3"	
KP-630-15	6"	13	17,5		171	167	150	133	120	103	64	3"	
KP-630-16	6"	15	20		183	178	161	143	130	112	70	3"	
KP-630-17	6"	15	20		195	190	170	150	138	119	74	3"	
KP-630-18	6"	18,5	25		207	202	182	162	149	129	82	3"	
KP-630-19	6"	18,5	25		218	213	193	170	155	135	85	3"	
KP-630-20	6"	18,5	25		229	223	202	179	164	140	88	3"	
KP-630-21	6"	18,5	25		240	234	211	188	170	148	92	3"	
KP-630-22	6"	22	30		252	247	222	198	180	156	99	3"	
KP-630-23	6"	22	30		263	257	233	206	188	162	101	3"	
KP-630-24	6"	22	30		275	268	242	214	195	168	105	3"	
KP-630-25	6"	22	30		285	278	250	222	200	175	109	3"	
KP-630-26	6"	22	30		296	288	260	230	208	180	111	3"	
KP-630-27	6"	26	35		310	301	274	242	220	190	121	3"	
KP-630-28	6"	26	35		320	312	283	250	228	199	124	3"	
KP-630-29	6"	26	35		331	323	292	258	235	202	128	3"	
KP-630-30	6"	26	35		342	333	300	266	241	209	130	3"	
KP-630-31	6"	30	40		353	344	310	274	249	215	132	3"	
KP-630-32	6"	30	40		368	358	325	288	261	226	142	3"	
KP-630-33	6"	30	40		378	369	334	295	269	231	145	3"	
KP-630-34	6"	30	40		390	380	343	302	275	238	149	3"	
KP-630-35	6"	30	40		400	390	352	310	282	242	152	3"	
KP-630-39	6"	37	50	445	436	395	350	320	279	178	3"		
KP-630-43	6"	37	50	489	478	432	482	350	301	190	3"		
KP-630-46	8"	45	60	531	521	475	425	390	340	220	3"		
KP-630-49	8"	45	60	565	555	505	450	412	360	231	3"		
KP-630-52	8"	55	75	602	591	540	480	442	389	251	3"		
KP-630-54	8"	55	75	625	612	560	500	459	400	260	3"		

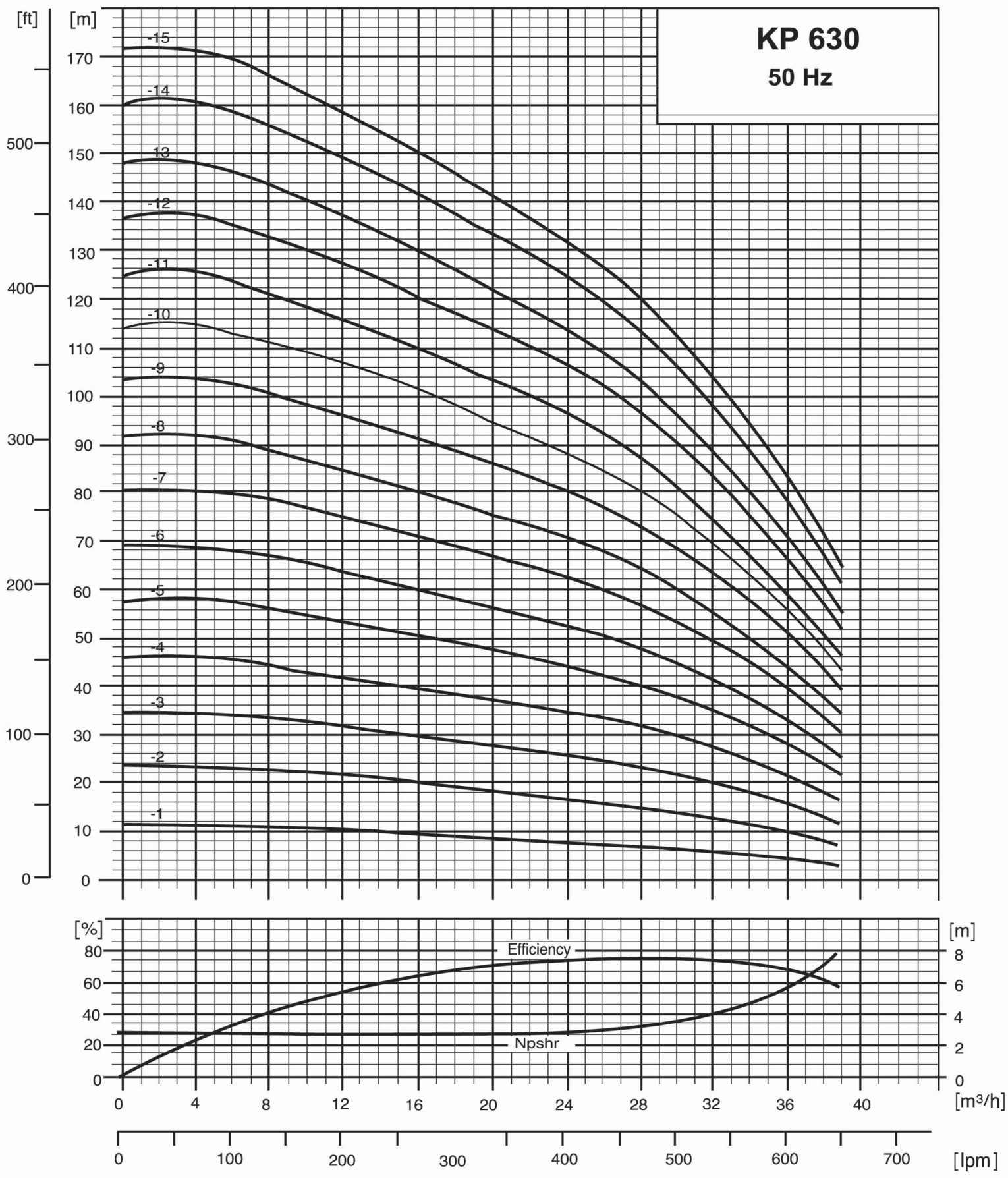

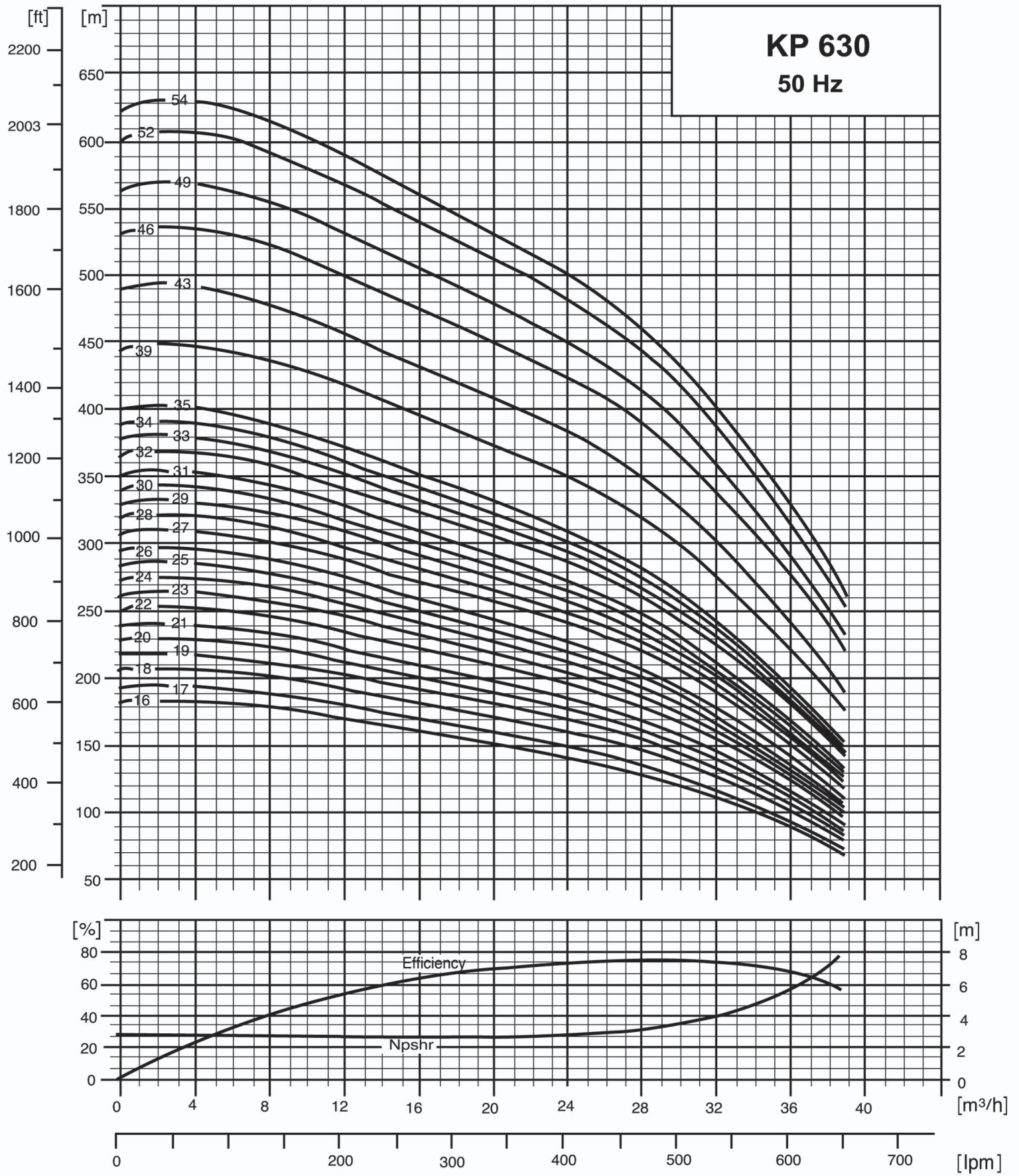

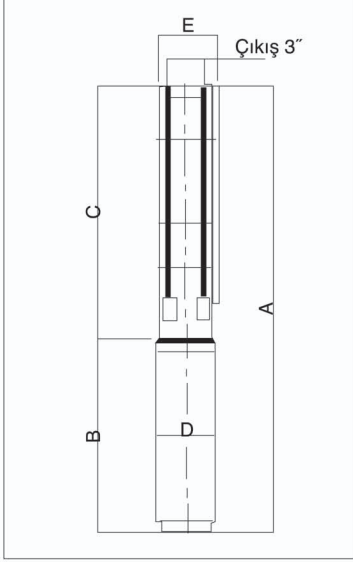

POMPA TIPI PUMP TYPE	MOTOR		POMPA EBAT ÖLÇÜLER PUMP DIMENSIONS (mm)						AĞIRLIK (kg)	WEIGHT (kg)
	TİP / TYPE	GÜÇ (kW) POWER	C	B	A	D	E*	E**		
KP 630-1	Motor 4"	1.1	349	536	855	95	131			25
KP 630-2	Motor 4"	2.2	445	636	1081	95	131			33
KP 630-3	Motor 4"	3	541	776	1317	95	131			40
KP 630-4	Motor 4"	4	637	776	1413	95	131			42
KP 630-5	Motor 4"	5.5	733	698	1431	95	131			44
KP 630-6	Motor 4"	5.5	829	698	1527	95	131			45
KP 630-7	Motor 4"	7.5	925	774	1699	95	131			50
KP 630-8	Motor 4"	7.5	1021	774	1795	95	131			52
KP 630-5	Motor 6"	5.5	733	698	1431	143	143	145		61
KP 630-6	Motor 6"	5.5	829	698	1527	143	143	145		62
KP 630-7	Motor 6"	7.5	925	748	1673	143	143	145		71
KP 630-8	Motor 6"	7.5	1021	748	1769	143	143	145		73
KP 630-9	Motor 6"	9.2	1133	788	1921	143	143	145		78
KP 630-10	Motor 6"	9.2	1229	788	2017	143	143	145		80
KP 630-11	Motor 6"	9.2	1325	788	1113	143	143	145		82
KP 630-12	Motor 6"	11	1425	866	2291	143	143	145		87
KP 630-13	Motor 6"	11	1517	866	2383	143	143	145		89
KP 630-14	Motor 6"	13	1613	878	2491	143	143	145		94
KP 630-15	Motor 6"	13	1709	878	2587	143	143	145		96
KP 630-16	Motor 6"	15	1805	923	2728	143	143	145		102
KP 630-17	Motor 6"	15	1901	923	2824	143	143	145		103
KP 630-18	Motor 6"	18.5	1997	1013	3010	143	143	145		115
KP 630-19	Motor 6"	18.5	2093	1013	3106	143	143	145		116
KP 630-20	Motor 6"	18.5	2189	1013	3202	143	143	145		118
KP 630-21	Motor 6"	18.5	2285	1013	3295	143	143	145		120
KP 630-22	Motor 6"	22	2381	1098	3479	143	143	145		129
KP 630-23	Motor 6"	22	2471	1098	3575	143	143	145		131
KP 630-24	Motor 6"	22	2573	1098	3671	143	143	145		132
KP 630-25	Motor 6"	22	2669	1098	3767	143	143	145		134
KP 630-26	Motor 6"	22	2765	1098	3863	143	143	145		136
KP 630-27	Motor 6"	26	2861	1193	4054	143	143	145		149
KP 630-28	Motor 6"	26	2957	1193	4150	143	143	145		151
KP 630-29	Motor 6"	26	3053	1193	4246	143	143	145		153
KP 630-30	Motor 6"	26	3149	1193	4342	143	143	145		154
KP 630-31	Motor 6"	30	3245	1233	4478	143	143	145		159
KP 630-32	Motor 6"	30	3341	1233	4574	143	143	145		160
KP 630-33	Motor 6"	30	3437	1233	4670	143	143	145		162
KP 630-34	Motor 6"	30	3533	1233	4766	143	143	145		163
KP 630-35	Motor 6"	30	3629	1233	4862	143	143	145		165
KP 630-39	Motor 6"	37	4260	1233	5493	143	143	145		172
KP 630-43	Motor 6"	37	4644	1233	5877	143	143	145		178
KP 630-39	Motor 6"	37	4260	1034	5294	188	188	188		209
KP 630-43	Motor 6"	37	4644	1034	5678	188	188	188		215
KP 630-46	Motor 8"	45	4881	1104	5985	188	188	188		240
KP 630-49	Motor 8"	45	5169	1104	6273	188	188	188		245
KP 630-52	Motor 8"	55	5457	1234	6691	188	188	188		250
KP 630-54	Motor 8"	55	5649	1234	6883	188	188	188		253

POMPA TiPi 6"	MOTOR			It/sec m3/h	DEBİ / FLOW							EXIT
	TiPi/TYPE	KW	HP		0.0 0	2.8 10	5.6 20	8.3 30	11.1 40	13.9 50	16.7 60	ÇIKIŞ Inch"
KP-646-01	4"	2,2	3	H(m)	14	13	12	10	7	6	4	3"
KP-646-02	4"	3	4		27	25	23	21	18	14	8	3"
KP-646-03	6"	5,5	7,5		41	40	38	32	28	23	15	3"
KP-646-04	6"	7,5	10		55	52	48	44	38	31	20	3"
KP-646-05	6"	7,5	10		67	64	59	54	47	37	24	3"
KP-646-06	6"	9,2	12,5		81	77	71	65	57	45	29	3"
KP-646-07	6"	11	15		94	90	84	76	66	51	35	3"
KP-646-08	6"	13	17,5		108	103	96	87	77	62	41	3"
KP-646-09	6"	15	20		122	117	107	99	87	70	47	3"
KP-646-10	6"	15	20		135	127	120	109	95	77	51	3"
KP-646-11	6"	18,5	25		149	143	133	121	106	86	58	3"
KP-646-12	6"	18,5	25		162	157	144	132	115	93	63	3"
KP-646-13	6"	18,5	25		177	169	157	143	126	102	69	3"
KP-646-14	6"	22	30		189	181	169	153	134	108	73	3"
KP-646-15	6"	22	30		210	193	180	163	142	115	77	3"
KP-646-16	6"	26	35		216	207	197	176	155	125	85	3"
KP-646-17	6"	26	35		230	220	205	186	163	132	90	3"
KP-646-18	6"	30	40		245	235	218	199	175	142	96	3"
KP-646-19	6"	30	40		257	247	230	209	184	148	100	3"
KP-646-20	6"	30	40		270	258	241	218	192	155	105	3"
KP-646-21	6"	37	50		285	274	255	234	205	168	115	3"
KP-646-22	6"	37	50		297	286	267	244	215	175	119	3"
KP-646-23	6"	37	50		312	297	278	254	224	181	124	3"
KP-646-24	6"	37	50		324	310	290	274	232	187	128	3"
KP-646-26	8"	45	60		357	343	321	295	260	214	147	3"
KP-646-28	8"	45	60		383	368	345	315	280	228	158	3"
KP-646-30	8"	45	60		410	394	368	337	298	244	168	3"
KP-646-33	8"	55	75		452	435	407	374	330	270	188	3"
KP-646-35	8"	55	75		479	460	430	395	349	285	198	3"
KP-646-37	8"	55	75		508	488	458	420	373	305	213	3"

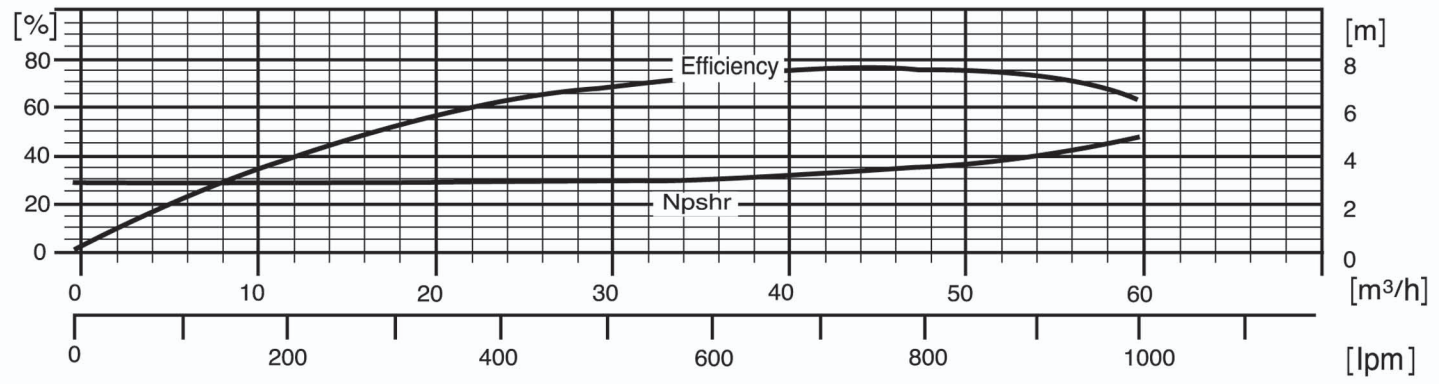
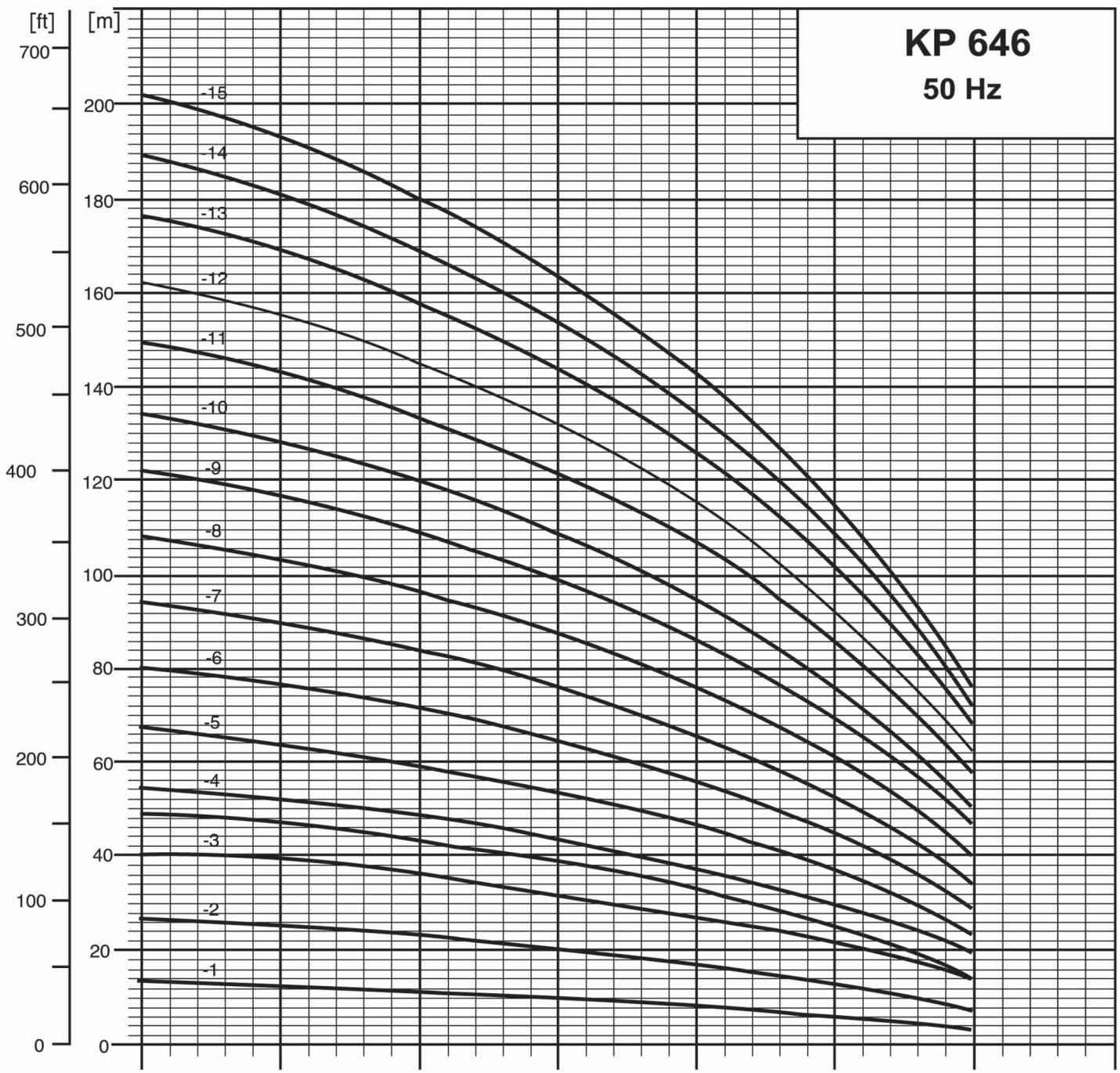

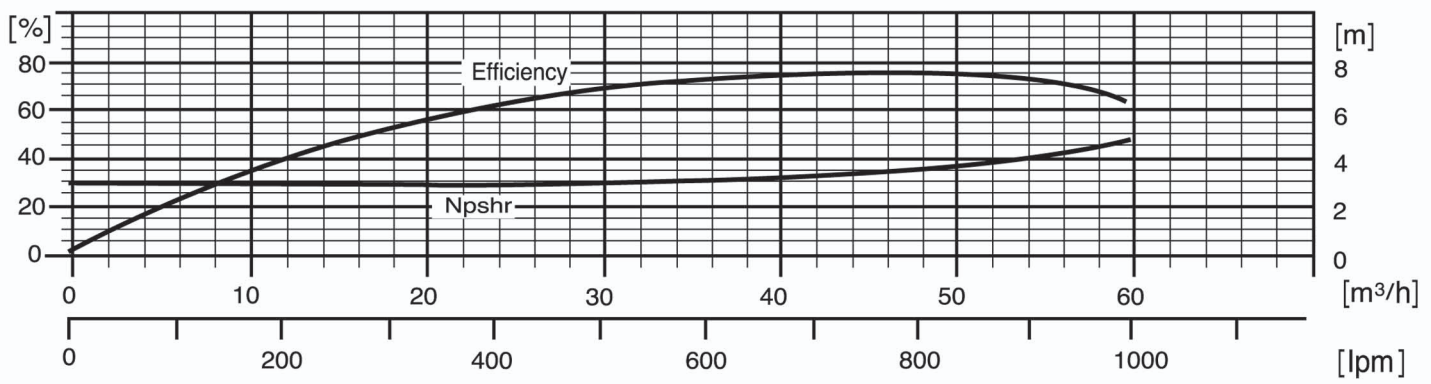
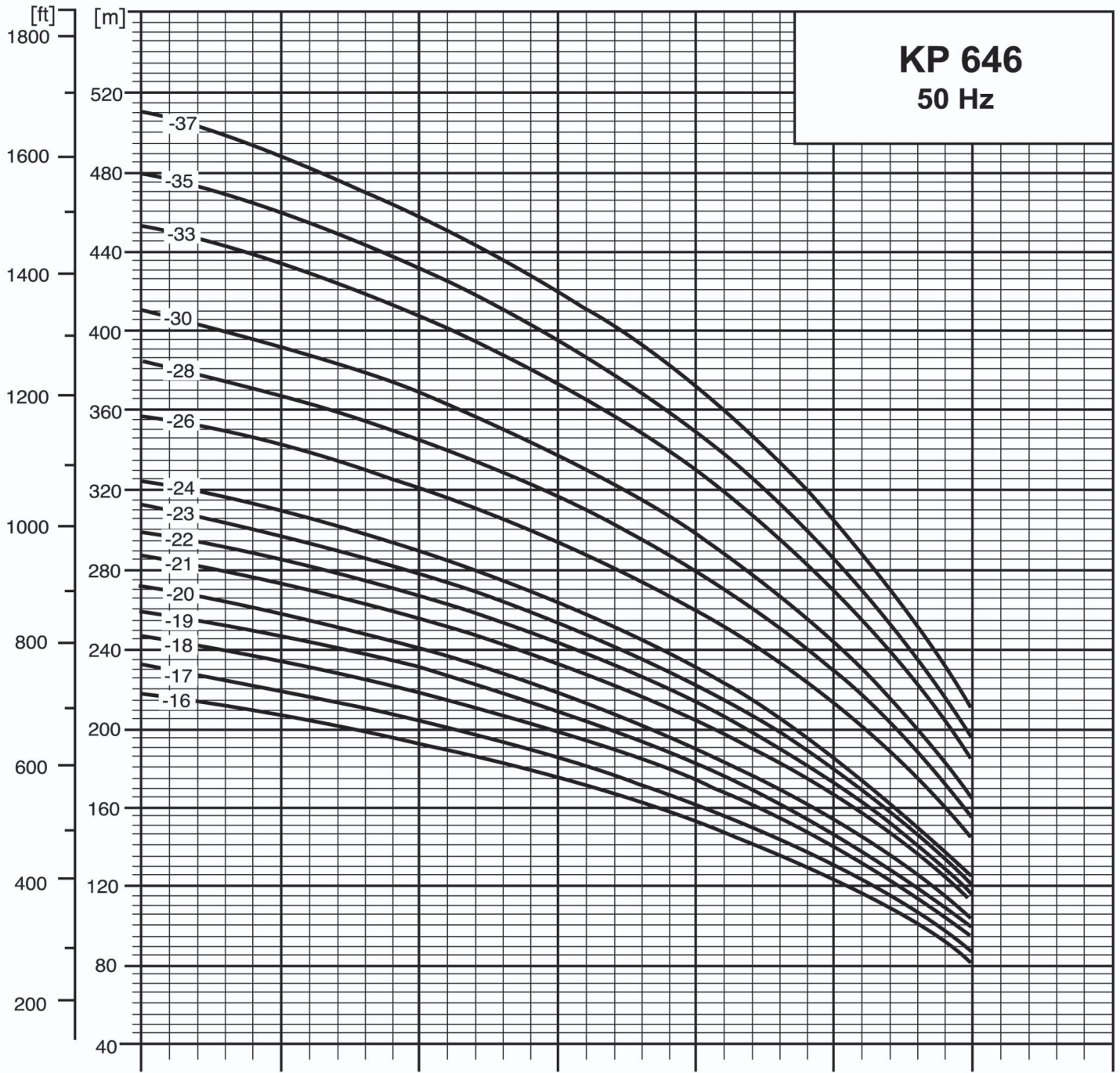

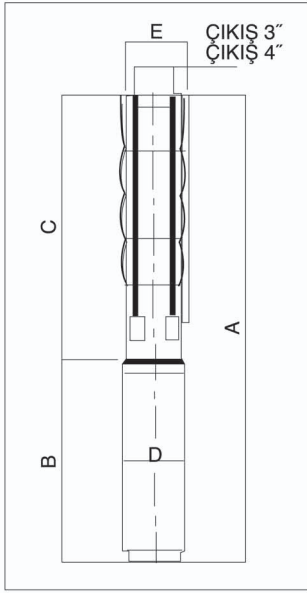

POMPA TİPİ PUMP TYPE	MOTOR		POMPA EBAT ÖLÇÜLER (mm) / PUMP DIMENSIONS (mm)								NET AĞIRLIK (kg) WEIGHT (kg)		
	TİP/ TYPE	GÜÇ (Kw) POWER	1/3 BAĞLANTILAR / 1/3 CONNECTIONS				1/4 BAĞLANTILAR / 1/4 CONNECTIONS						
			A	C	E*	E**	A	C	E*	E**		B	D
KP 646-1	Motor 4"	2.2	1000	364	141		1006	370	145		636	95	31
KP 646-2	Motor 4"	3	1253	477	141		1259	483	145		776	95	37
KP 646-3	Motor 4"	5.5	1288	590	141		1294	596	145		698	95	42
KP 646-4	Motor 4"	7.5	1477	703	141		1483	709	145		774	95	48
KP 646-5	Motor 4"	7.5	1590	816	141		1596	822	145		774	95	50
KP 646-6	Motor 6"	9.2	1733	945	145	150	1739	951	147	152	788	143	78
KP 646-7	Motor 6"	11.0	1891	1058	145	150	1897	1064	147	152	833	143	84
KP 646-8	Motor 6"	13.0	2049	1171	145	150	2055	1177	147	152	878	143	91
KP 646-9	Motor 6"	15.0	2207	1284	145	150	2213	1290	147	152	923	143	97
KP 646-10	Motor 6"	15.0	2320	1397	145	150	2326	1403	147	152	923	143	100
KP 646-11	Motor 6"	18.5	2523	1510	145	150	2529	1516	147	152	1013	143	112
KP 646-12	Motor 6"	18.5	2636	1623	145	150	2642	1629	147	152	1013	143	115
KP 646-13	Motor 6"	18.5	2749	1736	145	150	2755	1742	147	152	1013	143	117
KP 646-14	Motor 6"	22	2917	1819	145	150	2953	1885	147	152	1098	143	128
KP 646-15	Motor 6"	22	3060	1962	145	150	3066	1968	147	152	1098	143	130
KP 646-16	Motor 6"	26	3268	2075	145	150	3271	2081	147	152	1193	143	144
KP 646-17	Motor 6"	26	3381	2188	145	150	3387	2194	147	152	1193	143	146
KP 646-18	Motor 6"	30	3534	2301	145	150	3540	2307	147	152	1233	143	153
KP 646-19	Motor 6"	30	3647	2414	145	150	3653	2420	147	152	1233	143	155
KP 646-20	Motor 6"	30	3840	2607	145	150	3846	2613	147	152	1233	143	158
KP 646-21	Motor 6"	37	3754	2720	188	188	3760	2726	188	188	1034	188	197
KP 646-22	Motor 6"	37	3867	2833	188	188	3873	2839	188	188	1034	188	200
KP 646-23	Motor 6"	37	3980	2946	188	188	3986	2952	188	188	1034	188	202
KP 646-24	Motor 6"	37	4093	3059	188	188	4099	3065	188	188	1034	188	205
KP 646-26	Motor 8"	45					4507	3403	188	188	1104	188	230
KP 646-28	Motor 8"	45					4733	3629	188	188	1104	188	235
KP 646-30	Motor 8"	45					4959	3855	188	188	1104	188	240
KP 646-33	Motor 8"	55					5428	4194	188	188	1234	188	262
KP 646-35	Motor 8"	55					5654	4420	188	188	1234	188	267
KP 646-37	Motor 8"	55					5880	4646	188	188	1234	188	273

POMPA TIPI 6" PUMP TYPE 6"	MOTOR			It/sec m3/h	DEBİ / FLOW							EXIT
	TiPi/TYPE	KW	HP		0.0	5.55	11.11	13.88	16.66	19.44	21.66	ÇIKIŞ inch"
KP-660-01	4"	2,2	3	H(m)	13	13	9	8	7	4	1	4"
KP-660-02	6"	4	5,5		28	26	19	17	15	10	5	4"
KP-660-03	6"	5,5	7,5		42	39	30	26	23	16	10	4"
KP-660-04	6"	7,5	10		56	52	41	35	31	22	14	4"
KP-660-05	6"	9,2	12,5		71	66	51	44	39	28	18	4"
KP-660-06	6"	11	15		81	79	62	54	46	34	22	4"
KP-660-07	6"	13	17,5		100	92	73	63	54	40	26	4"
KP-660-08	6"	15	20		114	106	84	73	62	46	30	4"
KP-660-09	6"	18,5	25		130	120	96	83	71	54	36	4"
KP-660-10	6"	18,5	25		143	133	105	92	78	60	41	4"
KP-660-11	6"	22	30		158	147	116	102	86	67	45	4"
KP-660-12	6"	22	30		172	159	126	110	94	72	50	4"
KP-660-13	6"	26	35		188	174	138	120	102	79	55	4"
KP-660-14	6"	26	35		200	186	148	130	110	85	58	4"
KP-660-15	6"	26	35		217	198	156	137	115	89	60	4"
KP-660-16	6"	30	40		230	212	169	147	125	95	65	4"
KP-660-17	6"	30	40		242	222	178	155	132	100	68	4"
KP-660-18	6"	37	50		260	242	193	168	143	110	77	4"
KP-660-19	6"	37	50		272	255	203	177	151	117	80	4"
KP-660-20	6"	37	50		287	267	212	185	158	122	85	4"
KP-660-21	6"	37	50		300	280	222	194	165	128	90	4"
KP-660-22	8"	45	60		322	302	242	211	180	142	100	4"
KP-660-24	8"	45	60		350	327	262	229	195	154	107	4"
KP-660-26	8"	55	75		382	358	287	250	215	168	120	4"
KP-660-28	8"	55	75		410	384	308	268	230	180	128	4"
KP-660-30	8"	55	75		440	410	328	285	245	192	135	4"

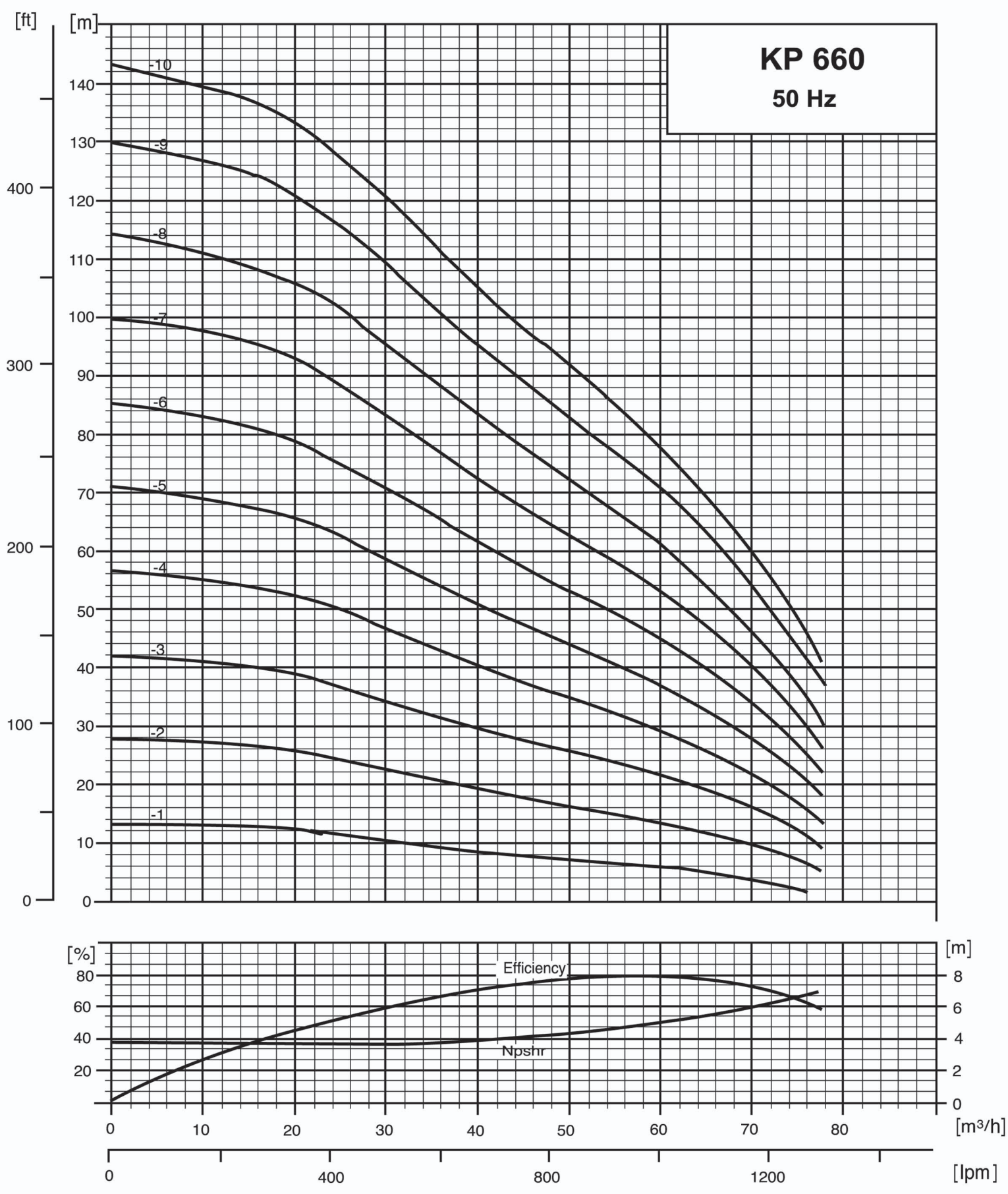

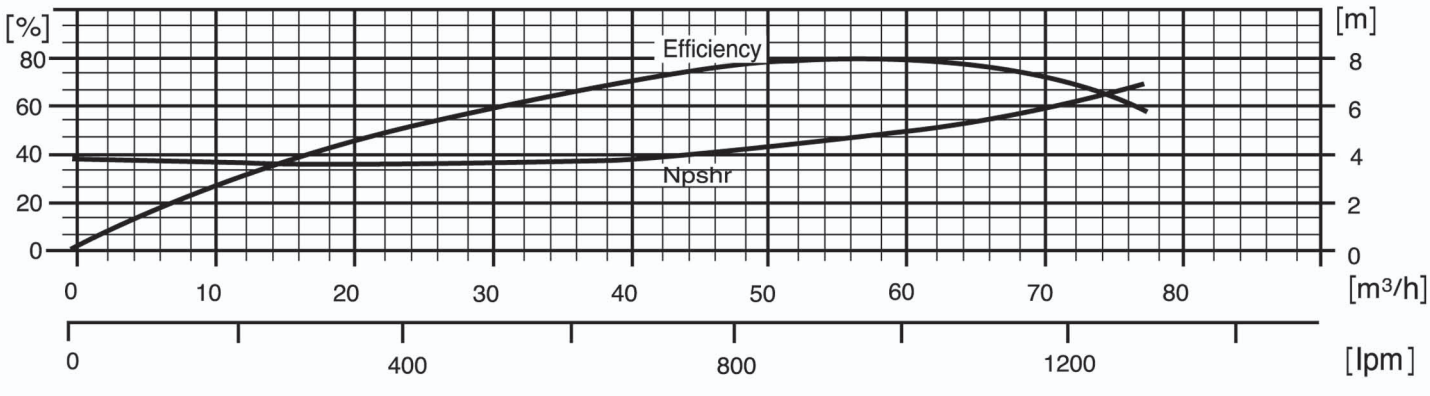
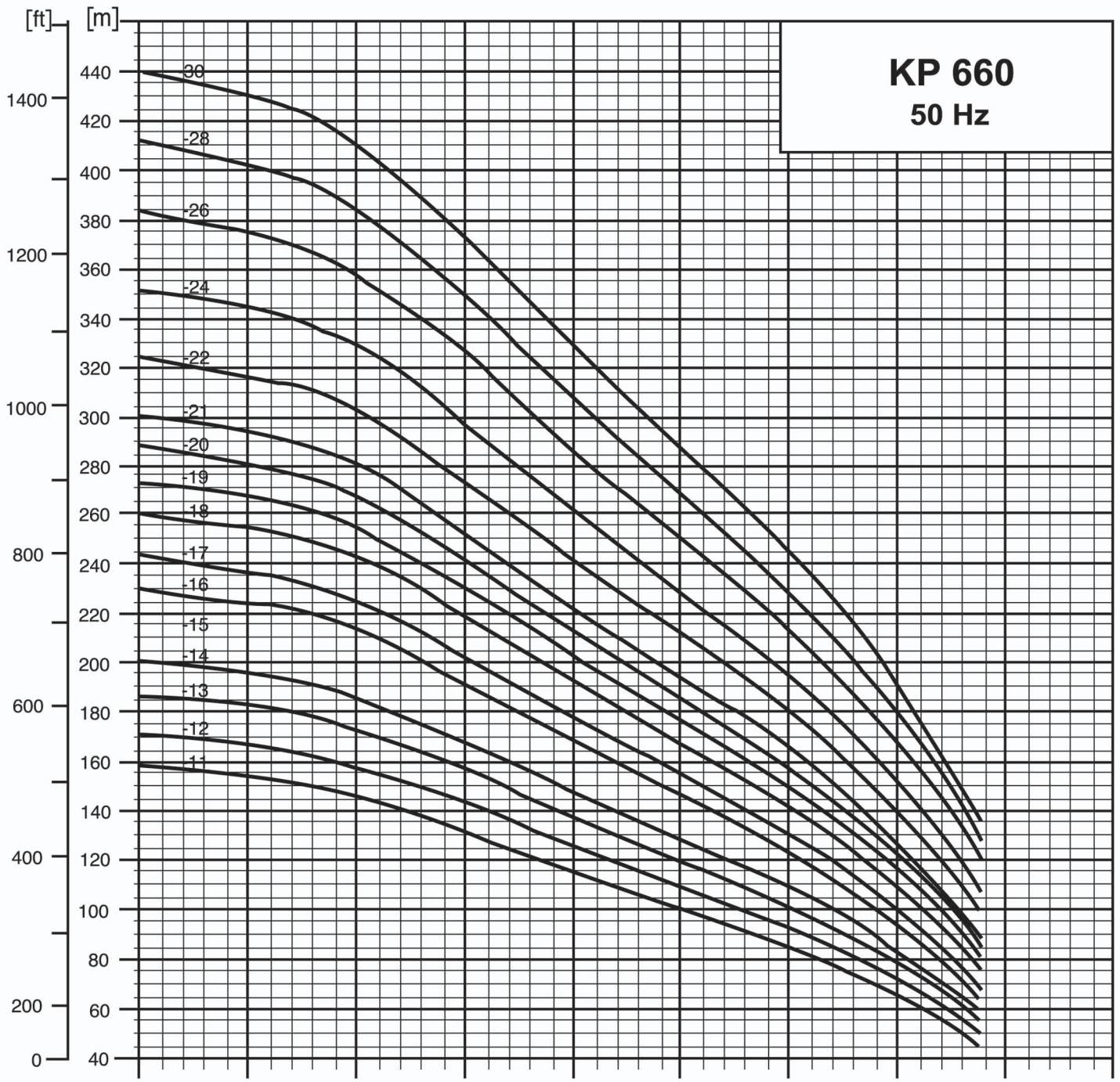

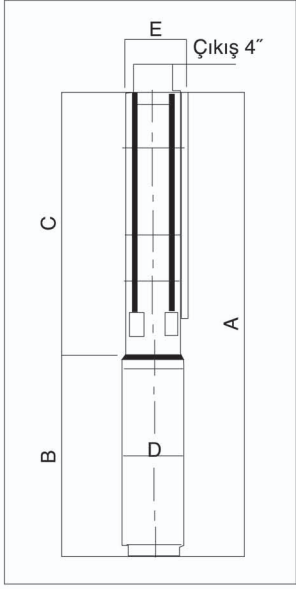

POMPA TIPI PUMP TYPE	MOTOR		POMPA EBAT ÖLÇÜLER (mm) / PUMP DIMENSIONS (mm)								NET AĞIRLIĞI (kg) WEIGHT (kg)		
	TİP / TYPE	GÜÇ (Kw) POWER	1/3 Bağlantılar / 1/3 CONNECTIONS				1/4 Bağlantılar / 1/4 CONNECTIONS						
			A	C	E*	E**	A	C	E*	E**		B	D
KP 660-1	Motor 4"	2.2	1000	364	141		1006	370	145		636	95	31
KP 660-2	Motor 4"	4	1253	477	141		1259	483	145		776	95	39
KP 660-3	Motor 4"	5.5	1288	590	141		1294	596	145		698	95	42
KP 660-4	Motor 4"	7.5	1477	703	141		1483	709	145		774	95	48
KP 660-5	Motor 6"	9.2	1620	832	145	150	1626	838	147	152	788	143	75
KP 660-6	Motor 6"	11	1783	950	145	150	1789	956	147	152	833	143	82
KP 660-7	Motor 6"	13	1936	1058	145	150	1942	1064	147	152	878	143	88
KP 660-8	Motor 6"	15	2094	1171	145	150	2100	1177	147	152	923	143	95
KP 660-9	Motor 6"	18.5	2297	1284	145	150	2303	1290	147	152	1013	143	107
KP 660-10	Motor 6"	18.5	2410	1397	145	150	2416	1403	147	152	1013	143	110
KP 660-11	Motor 6"	22	2608	1510	145	150	2614	1516	147	152	1098	143	120
KP 660-12	Motor 6"	22	2721	1623	145	150	2727	1629	147	152	1098	143	123
KP 660-13	Motor 6"	26	2929	1736	145	150	2935	1742	147	152	1193	143	136
KP 660-14	Motor 6"	26	3042	1849	145	150	3048	1855	147	152	1193	143	139
KP 660-15	Motor 6"	26	3155	1962	145	150	3161	1968	147	152	1193	143	141
KP 660-16	Motor 6"	30	3308	2075	145	150	3314	2081	147	152	1233	143	148
KP 660-17	Motor 6"	30	3421	2188	145	150	3427	2194	147	152	1233	143	150
KP 660-18	Motor 6"	37	3415	2381	188	188	3421	2387	188	188	1034	188	190
KP 660-19	Motor 6"	37	3528	2494	188	188	3534	2500	188	188	1034	188	192
KP 660-20	Motor 6"	37	3641	2607	188	188	3647	2613	188	188	1034	188	195
KP 660-21	Motor 6"	37	3826	2722	188	188	3832	2728	188	188	1104	188	197
KP 660-22	Motor 8"	45	3888	2784	188	188	3892	2788	188	188	1104	188	220
KP 660-24	Motor 8"	45					4281	3177	188	188	1104	188	225
KP 660-26	Motor 8"	55					4637	3403	188	188	1234	188	245
KP 660-28	Motor 8"	55					4863	3629	188	188	1234	188	250
KP 660-30	Motor 8"	55					5089	3855	188	188	1234	188	255

POMPA TiPi 8" PUMP TYPE 8"	MOTOR		lt/sec	DEBİ / FLOW								EXIT
	TiPi/TYPE	KW	HP	m3/h	0.0	5.6	11.1	16.7	19.4	22.2	27.8	ÇIKIŞ Inch'
KP-877-01	6"	5,5	7,5	H(m)	21	20	17	14	13	11	7	5"
KP-877-02	6"	7,5	10		41	39	33	28	26	23	13	5"
KP-877-03	6"	11	15		61	58	50	43	39	34	20	5"
KP-877-04	6"	15	20		81	78	68	57	52	46	27	5"
KP-877-05	6"	18,5	25		101	97	85	72	66	58	34	5"
KP-877-06	6"	22	30		120	116	102	88	78	69	40	5"
KP-877-07	6"	26	35		140	136	119	101	92	81	47	5"
KP-877-08	6"	30	40		160	156	136	115	105	93	55	5"
KP-877-09	6"	30	40		179	174	152	128	117	103	61	5"
KP-877-10	6"	37	50		199	194	170	145	132	116	69	5"
KP-877-11	6"	37	50		218	212	186	158	144	126	74	5"
KP-877-12	8"	45	60		243	237	210	178	163	145	87	5"
KP-877-13	8"	55	75		264	258	228	195	178	159	98	5"
KP-877-14	8"	55	75		283	277	245	209	191	170	103	5"
KP-877-15	8"	55	75		303	296	262	222	204	180	110	5"
KP-877-16	8"	66	90		324	317	280	240	220	195	119	5"
KP-877-17	8"	66	90		344	336	293	243	232	205	125	5"
KP-877-18	8"	66	90		342	355	313	267	245	216	132	5"
KP-877-19	8"	75	100		382	375	332	282	260	230	140	5"
KP-877-20	8"	75	100		402	395	348	296	272	240	145	5"
KP-877-21	8"	75	100		422	414	365	310	283	250	162	5"
KP-877-22	8"	93	125		441	433	380	324	296	262	168	5"

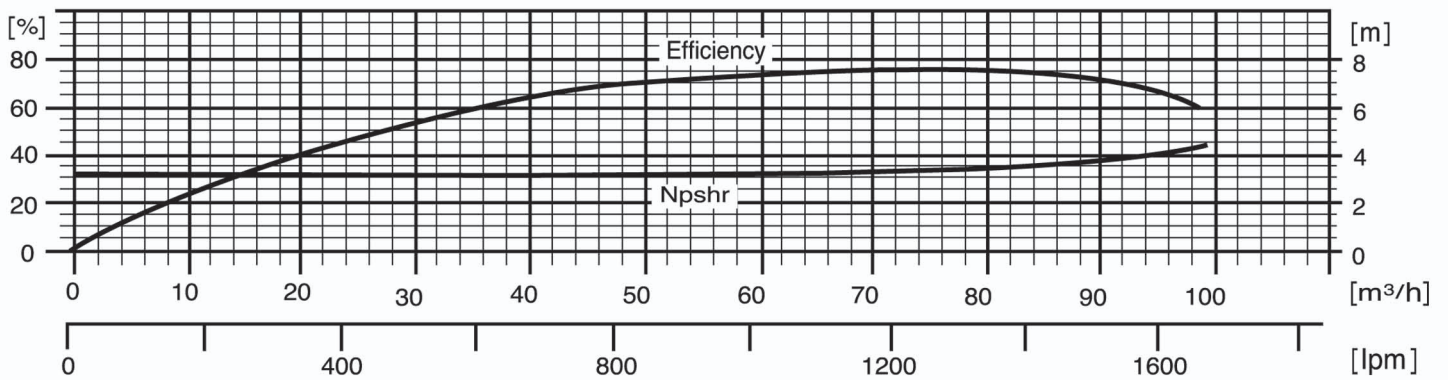
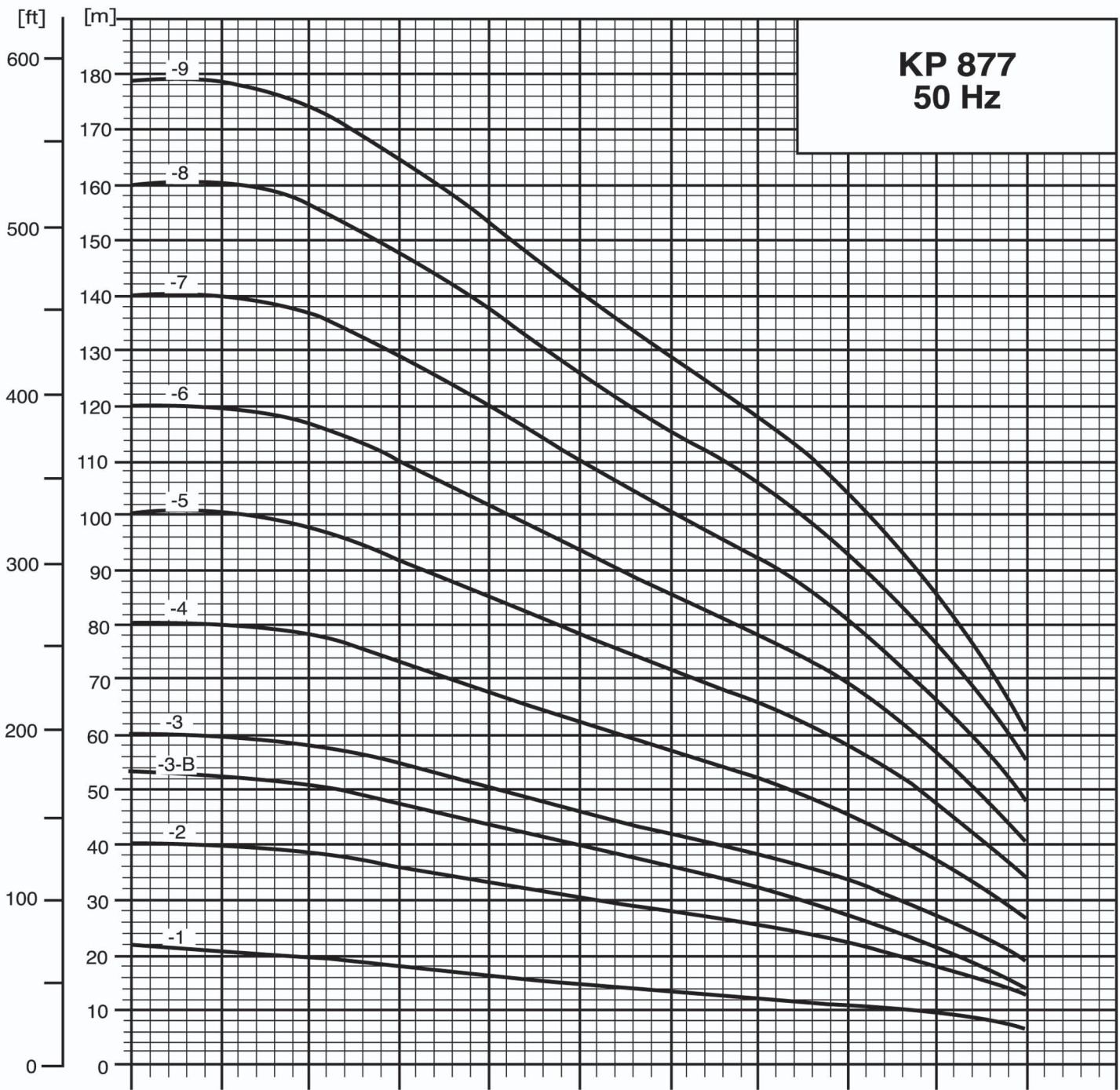

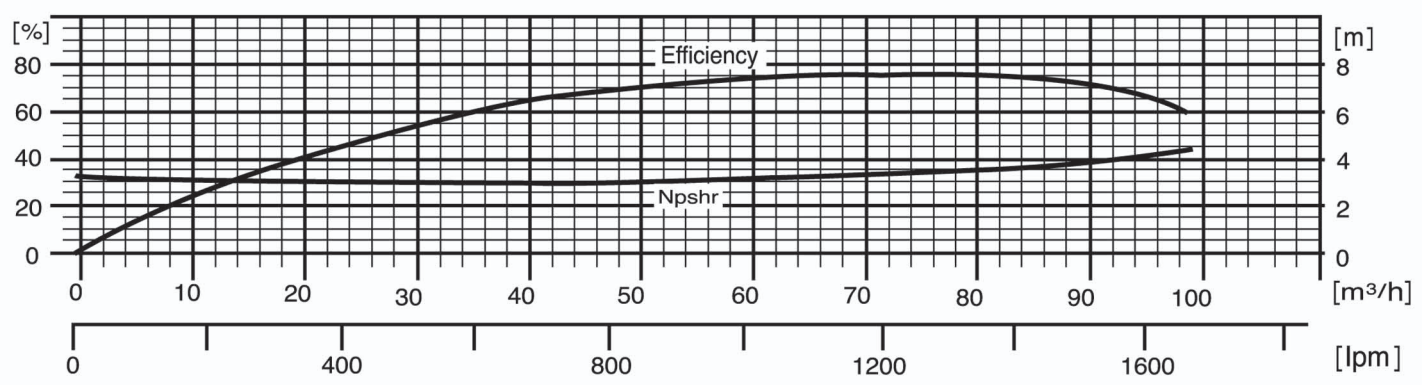
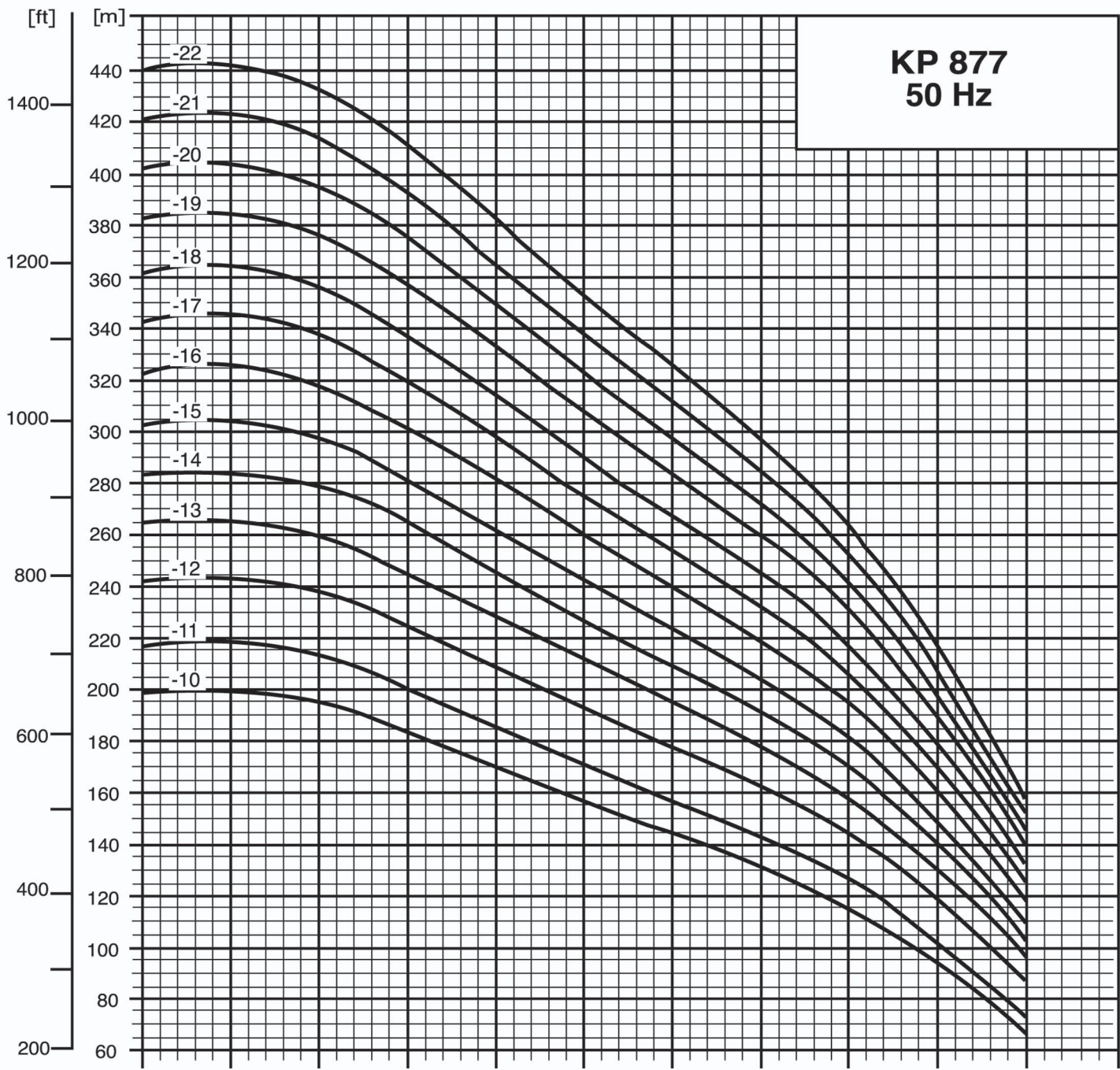

POMPA TiPi 8" PUMP TYPE 8"	MOTOR			lt/sec m3/h	DEBİ / FLOW							EXIT ÇIKIŞ inch"
	TiPi / TYPE	KW	HP		0,0	5,6	11,1	16,7	22,2	27,8	33,3	
KP-895-01	6"	5,5	7,5	H(m)	23	21	18	15	13	11	6	5"
KP-895-02	6"	9,2	12,5		44	41	38	31	27	22	8	5"
KP-895-03	6"	13	17,5		65	62	54	47	42	34	20	5"
KP-895-04	6"	18,5	25		86	82	72	63	55	44	26	5"
KP-895-05	6"	22	30		106	101	90	78	69	55	32	5"
KP-895-06	6"	30	40		128	123	110	96	84	68	40	5"
KP-895-07	6"	30	40		148	142	126	110	96	77	45	5"
KP-895-08	6"	37	50		168	162	145	127	112	90	54	5"
KP-895-09	6"	37	50		190	182	162	142	124	100	59	5"
KP-895-10	6"	45	60		215	206	185	162	143	115	70	5"
KP-895-11	8"	55	75		236	227	205	180	158	130	80	5"
KP-895-12	8"	55	75		247	247	222	195	172	140	85	5"
KP-895-13	8"	55	75		278	267	240	210	185	150	90	5"
KP-895-14	8"	66	90		300	288	260	227	200	162	100	5"
KP-895-15	8"	66	90		322	310	278	244	215	175	108	5"
KP-895-16	8"	75	100		342	330	295	260	230	185	119	5"
KP-895-17	8"	75	100		362	349	313	275	242	195	120	5"
KP-895-18	8"	93	125		382	368	330	290	255	205	125	5"
KP-895-19	8"	93	125		408	388	347	305	268	215	130	5"
KP-895-20	8"	93	125		422	407	365	320	281	225	135	5"

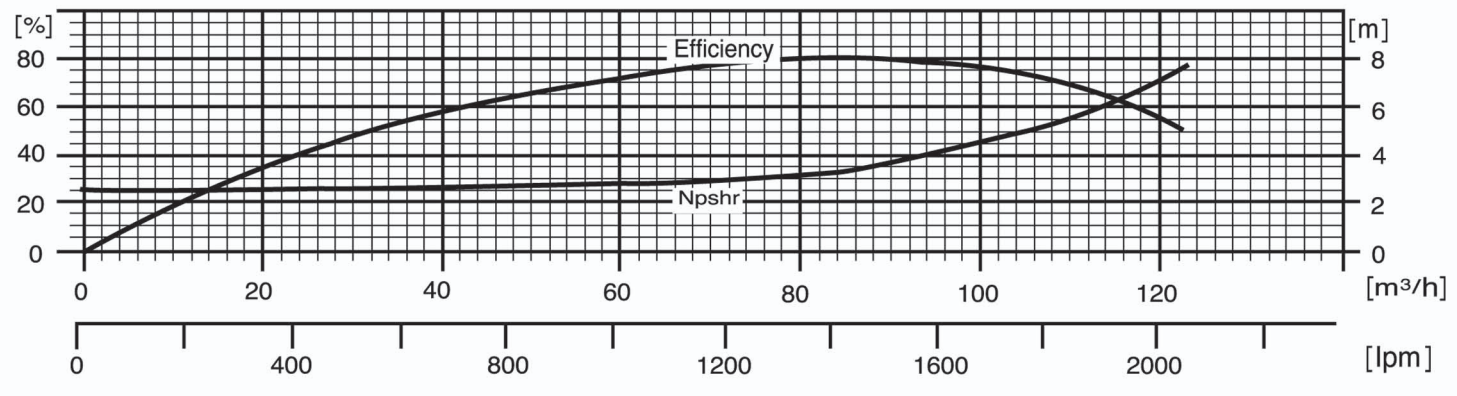
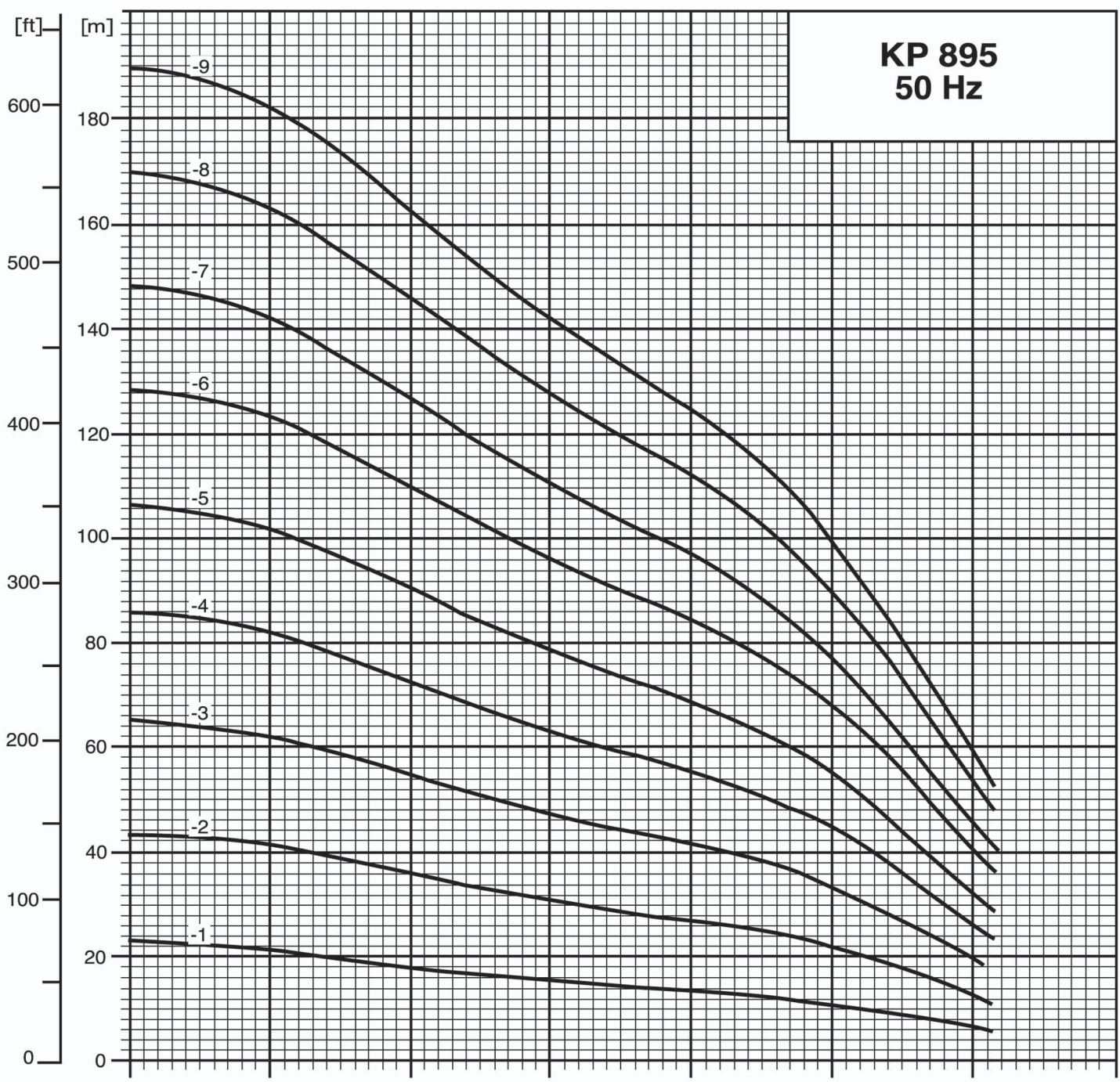

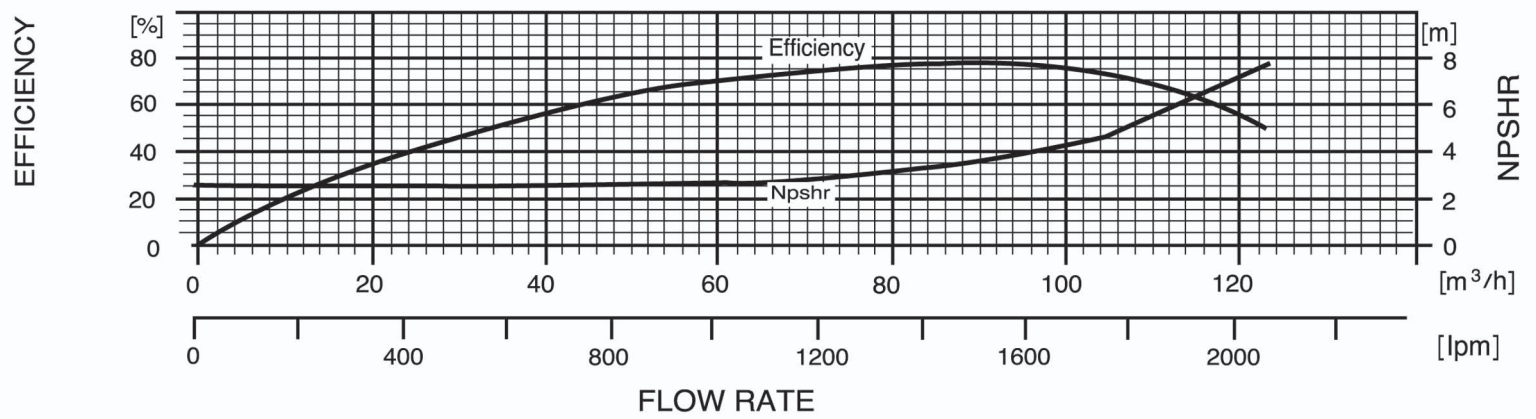
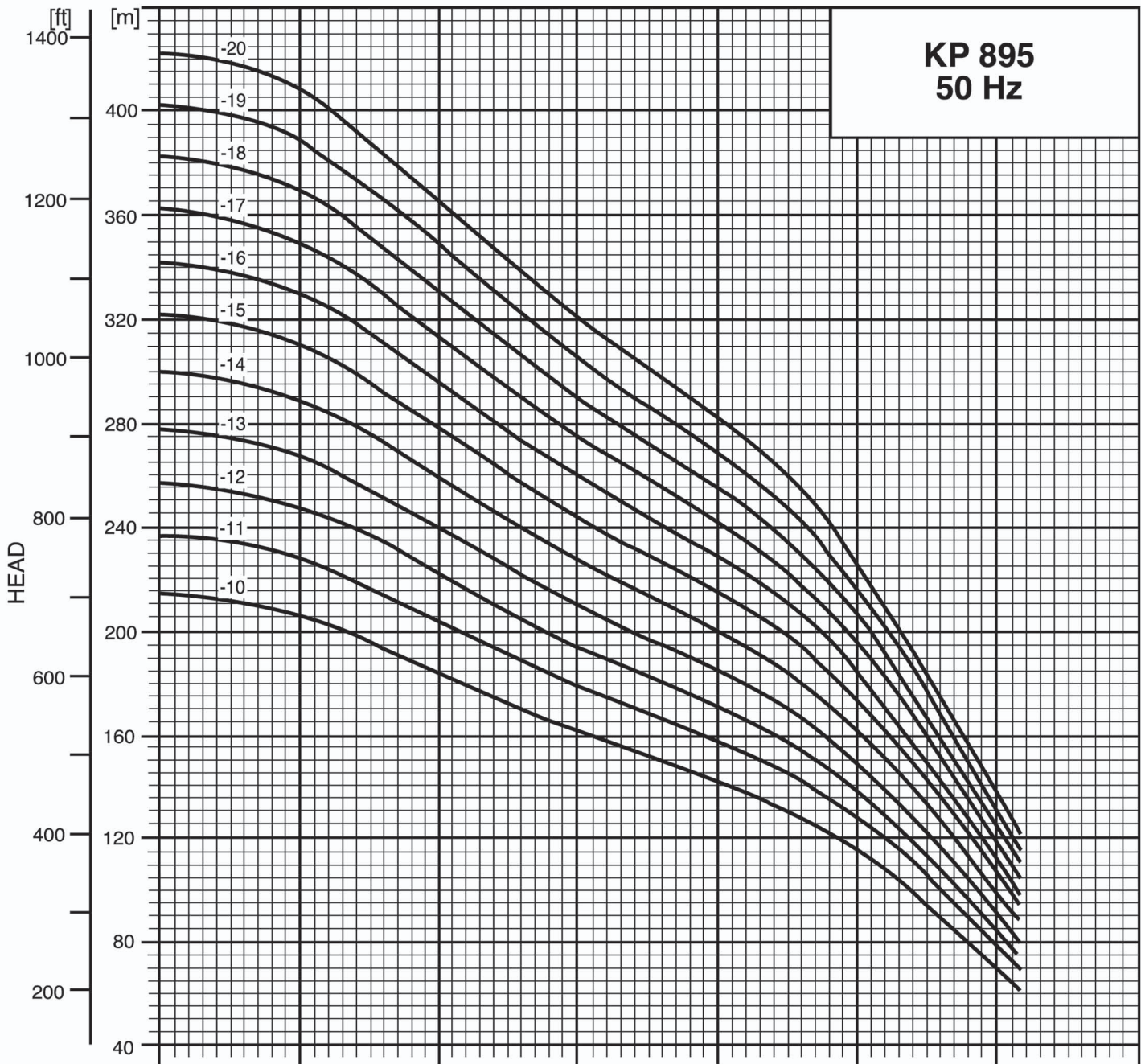

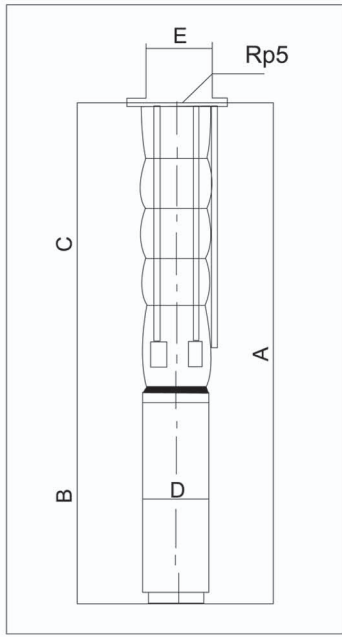

POMPA TİPİ PUMP TYPE	MOTOR		POMPA EBAT ÖLÇÜLERİ (mm) / PUMP DIMENSIONS (mm)										AĞIRLIK (kg)
	TİP / TYPE	GÜÇ (kw)	A	C	E*	E**	A	C	E*	E**	B	D	WEIGHT (kg)
KP 895-1	Motor 6"	5.5	1315	618	178	186	1316	618	200	200	698	143	66
KP 895-2	Motor 6"	9.2	1534	746	178	186	1534	746	200	200	788	143	81
KP 895-3	Motor 6"	13	1752	874	178	186	1752	874	200	200	878	143	95
KP 895-4	Motor 6"	18.5	2016	1003	178	186	2016	1003	200	200	1013	143	112
KP 895-5	Motor 6"	22	2229	1131	178	186	2229	1131	200	200	1098	143	124
KP 895-6	Motor 6"	26	2452	1259	178	186	2452	1259	200	200	1193	143	140
KP 895-7	Motor 6"	30	2620	1387	178	186	2620	1387	200	200	1233	143	150
KP 895-8	Motor 6"	37	2748	1515	178	186	2748	1515	200	200	1233	143	155
KP 895-4	Motor 8"	18.5	1797	1003	196	204	1797	1003	205	205	794	188	128
KP 895-5	Motor 8"	22	1985	1131	196	204	1985	1131	205	205	854	188	149
KP 895-6	Motor 8"	26	2193	1259	196	204	2193	1259	205	205	934	188	164
KP 895-7	Motor 8"	30	2321	1387	196	204	2321	1387	205	205	934	188	173
KP 895-8	Motor 8"	37	2549	1515	196	204	2549	1515	205	205	1034	188	212
KP 895-9	Motor 8"	45	2746	1647	196	204	2746	1647	205	205	1104	188	230
KP 895-10	Motor 8"	45	2889	1785	196	204	2889	1785	205	205	1104	188	235
KP 895-11	Motor 8"	55	3148	1914	196	204	3148	1914	205	205	1234	188	235
KP 895-12	Motor 8"	55	3277	2043	196	204	3277	2043	205	205	1234	188	240
KP 895-13	Motor 8"	55	3406	2172	196	204	3406	2172	205	205	1234	182	244
KP 895-14	Motor 8"	63	3790	2300	196	204	37790	2300	205	205	1490	192	290
KP 895-15	Motor 8"	75	3989	2429	196	204					1560	192	296
KP 895-16	Motor 8"	75	4117	2557	196	204					1560	192	300
KP 895-17	Motor 8"	75	4245	2685	196	204					1560	192	305
KP 895-18	Motor 8"	92	4848	3108	196	204					1740	192	341
KP 895-19	Motor 8"	92	4976	3236	196	204					1740	192	346
KP 895-20	Motor 8"	92	5104	3364	196	204					1740	192	350

POMPA TİPİ	PUMP TYPE	MOTOR		Q	DEBİ / FLOW						
					m3/h	0	40	80	100	120	140
10"	TİPİ	KW	HP	lt/sec	0	11	22	28	33	39	44
KP 10125-1	6"	11	15	H(m)	30	29	24	22	20	17	13
KP 10125-2	6"	22	30		59	57	49	46	41	35	27
KP 10125-3	6"	30	40		88	86	74	69	62	53	40
KP 10125-4	6"	37	50		115	113	99	91	83	70	54
KP 10125-5	8"	55	75		146	145	127	118	108	93	72
KP 10125-6	8"	66	90		175	174	152	142	130	112	87
KP 10125-7	8"	75	100		204	202	178	165	151	130	100
KP 10125-8	8"	75	100		232	230	202	188	171	146	113
KP 10125-9	8"	92	125		260	257	225	210	190	163	125
KP 10125-10	8"	92	125		288	284	249	236	210	179	137
KP 10125-11	10"	110	150		318	314	275	256	234	199	155
KP 10125-12	10"	132	180		350	347	306	286	261	224	177
KP 10125-13	10"	132	180		378	375	331	308	280	242	188
KP 10125-14	10"	147	200		408	406	359	335	306	263	206
KP 10125-15	10"	147	200		436	435	383	358	327	280	220
KP 10125-16	10"	170	230		466	465	409	382	350	300	238
KP 10125-17	10"	170	230		495	473	434	405	370	318	250

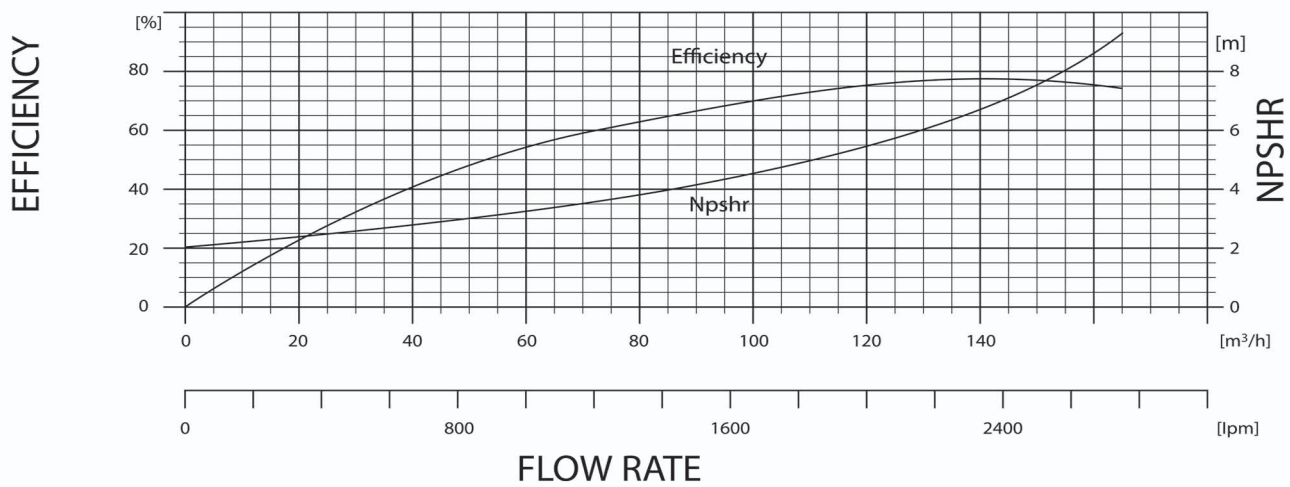
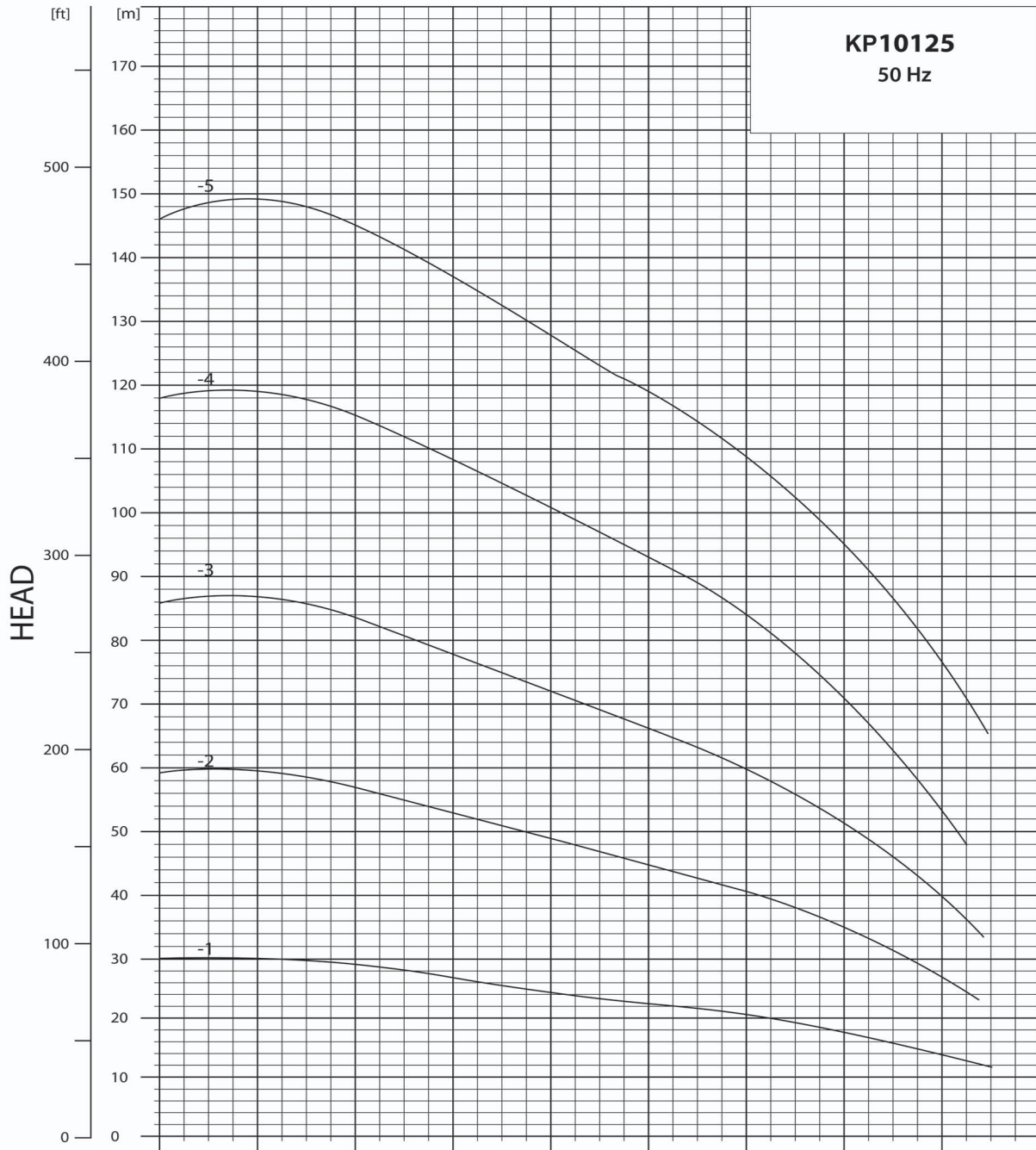

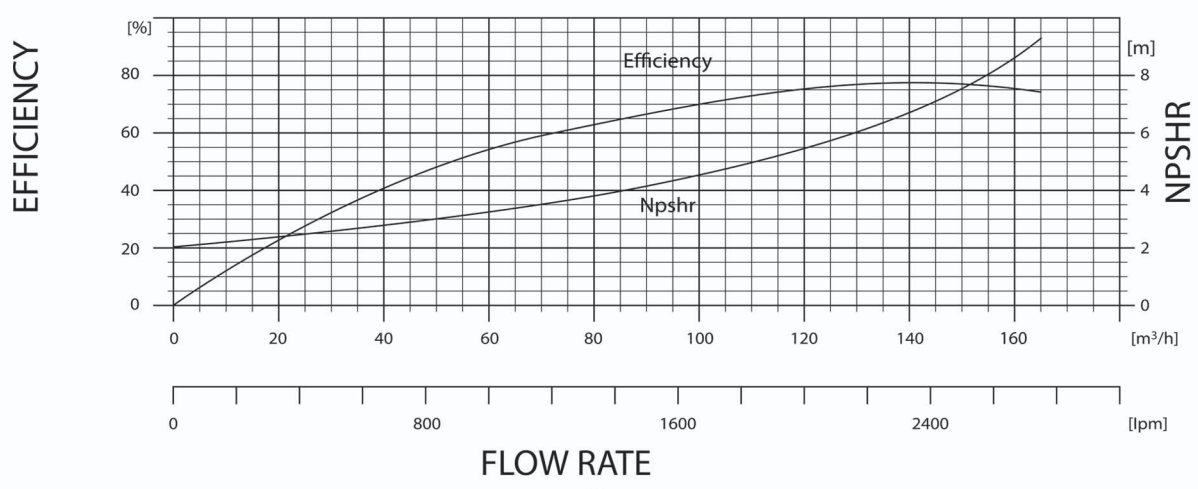
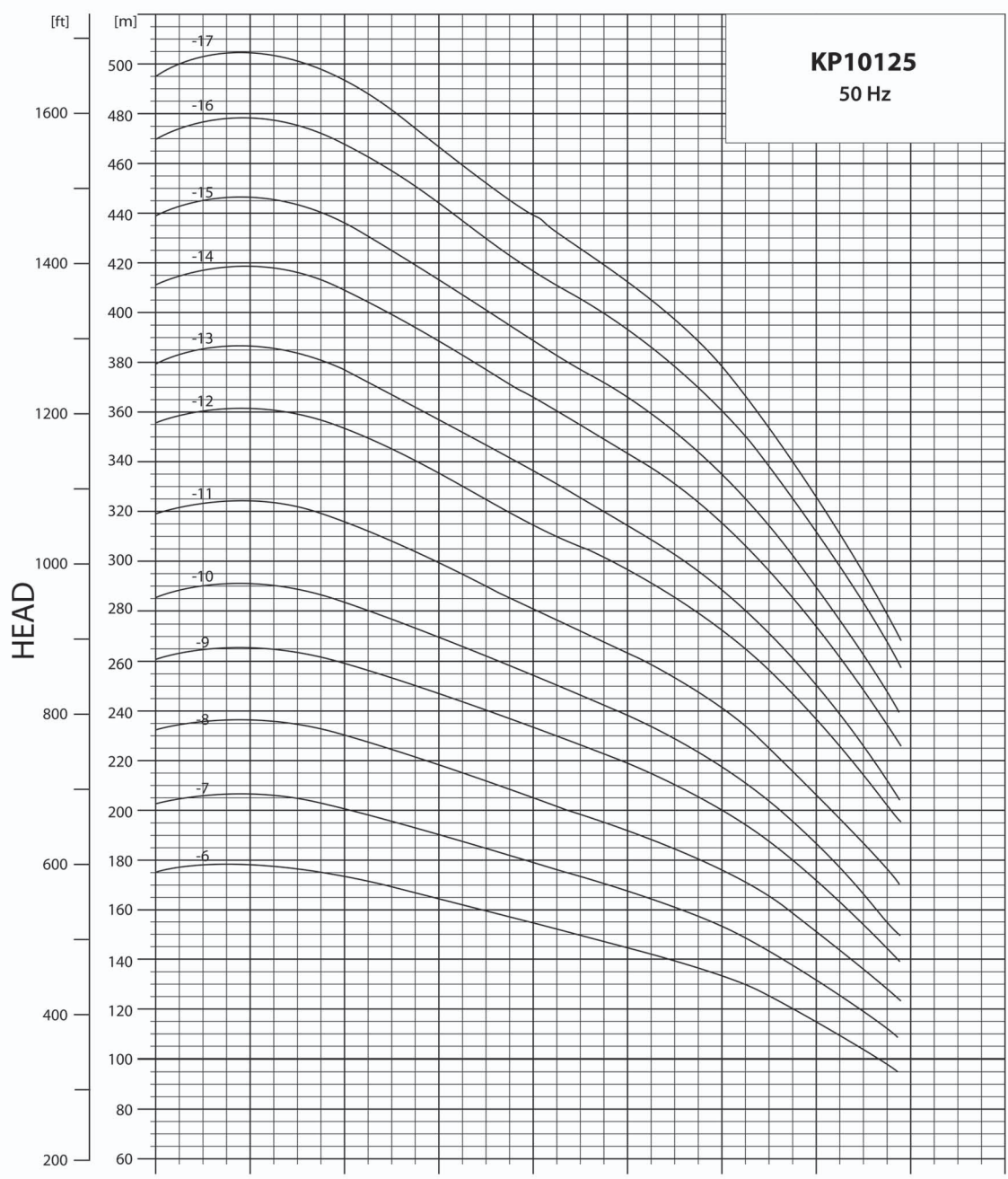

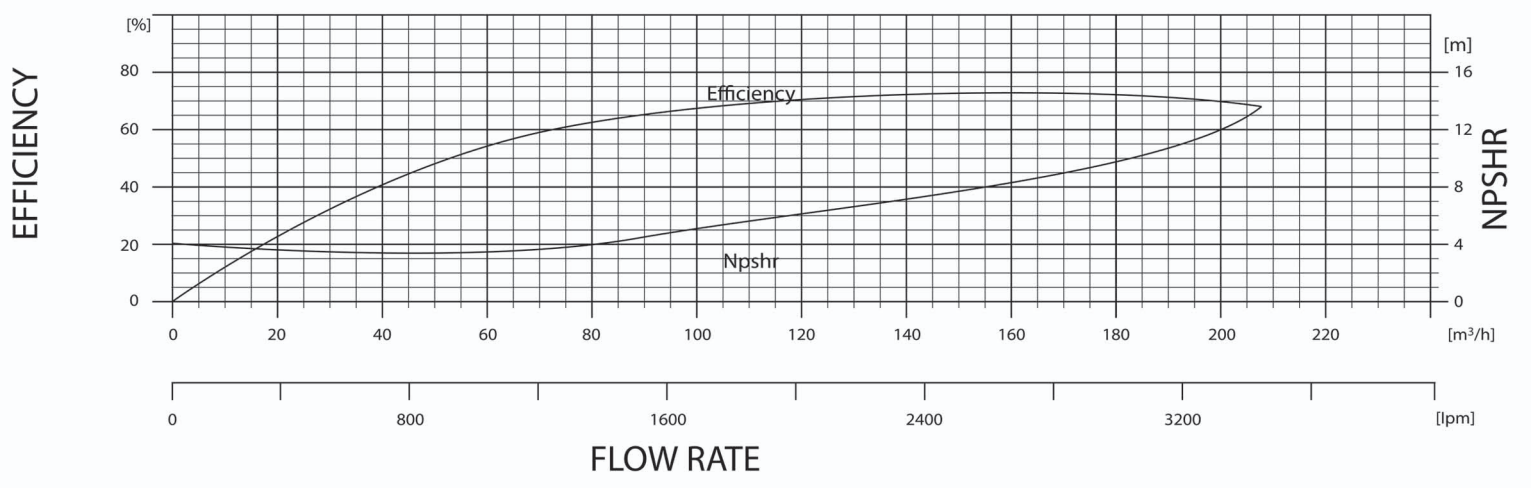
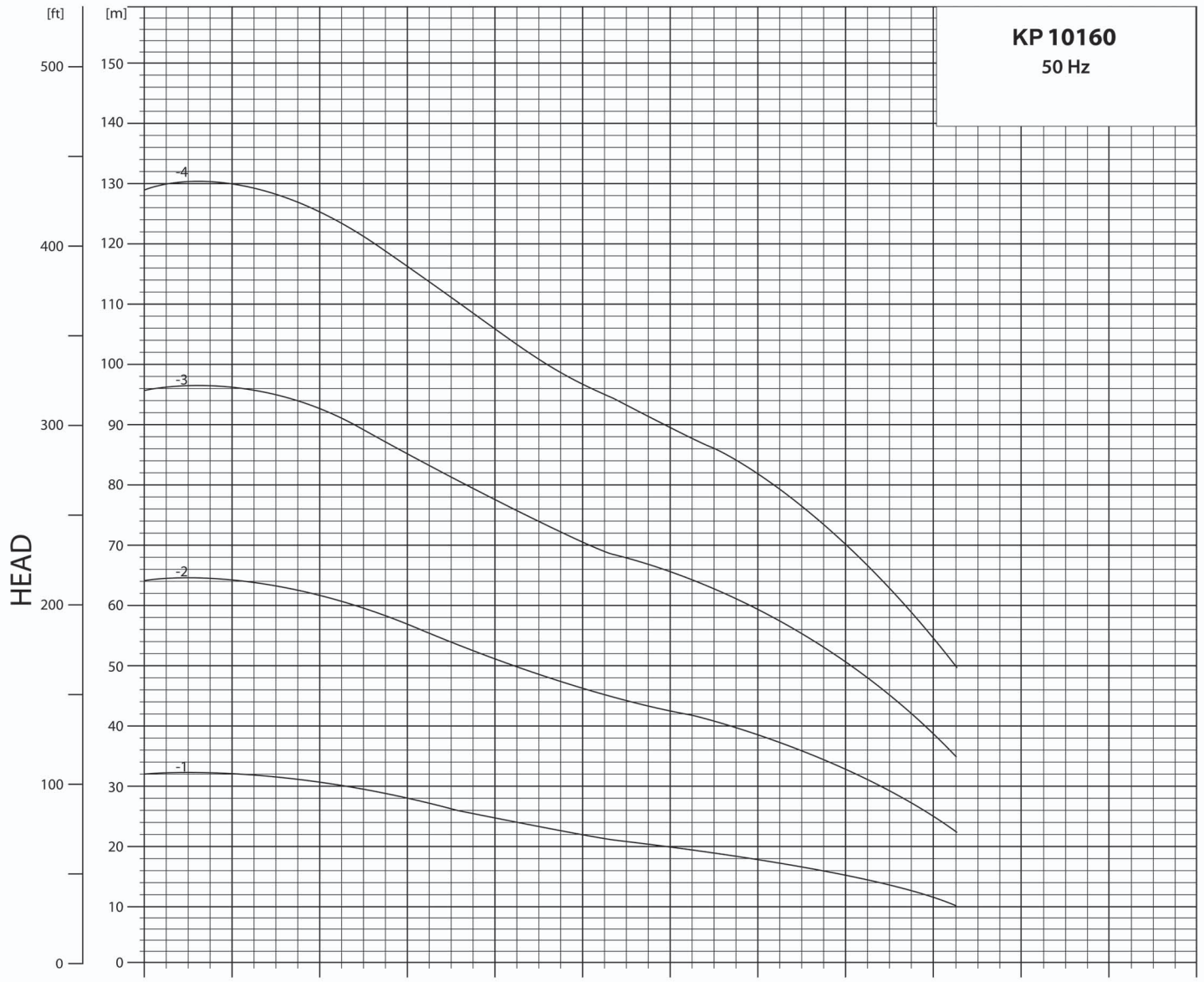

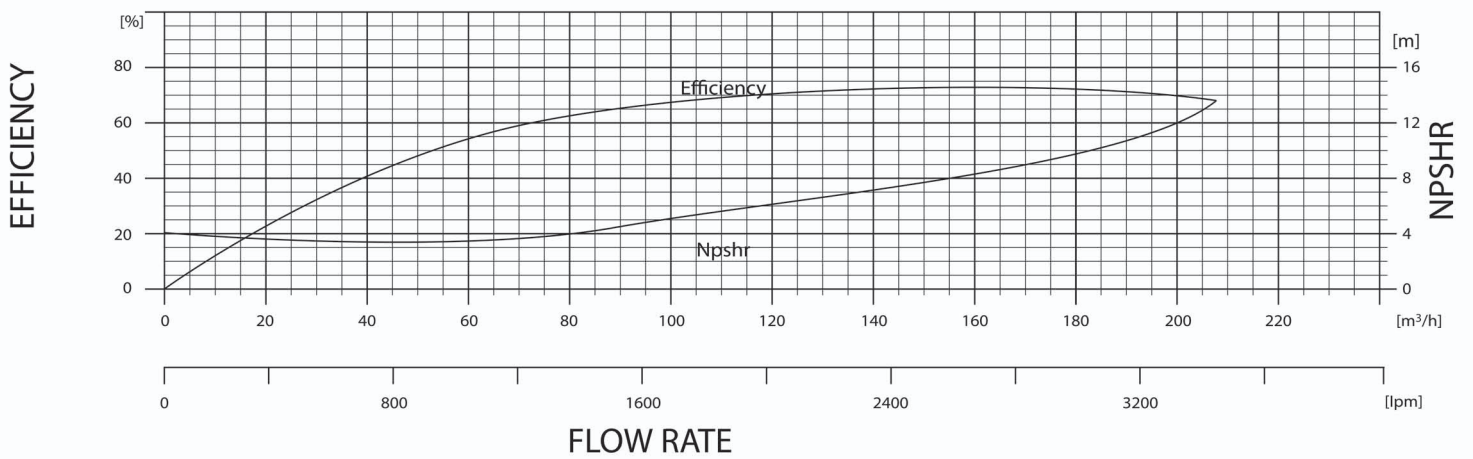
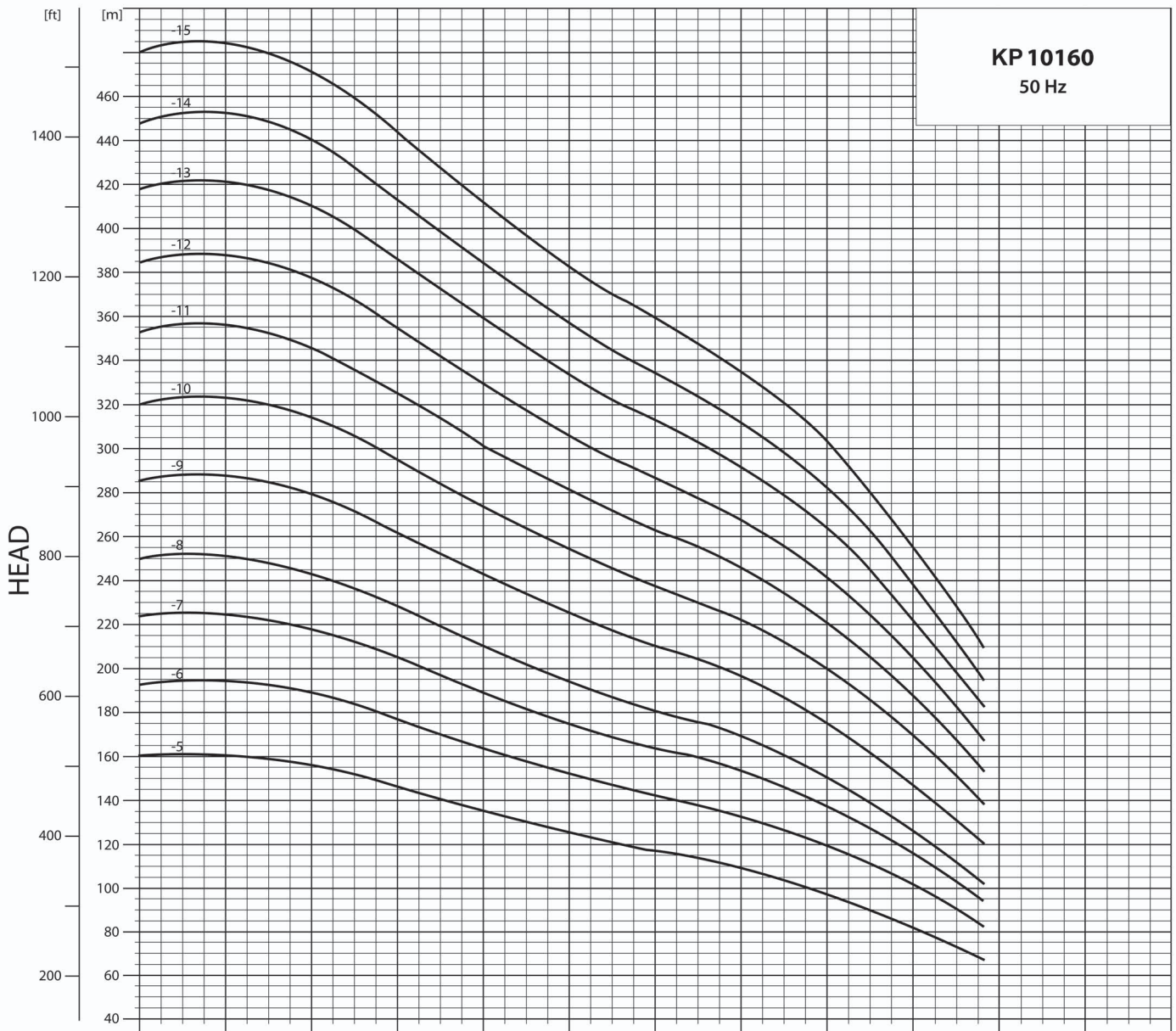

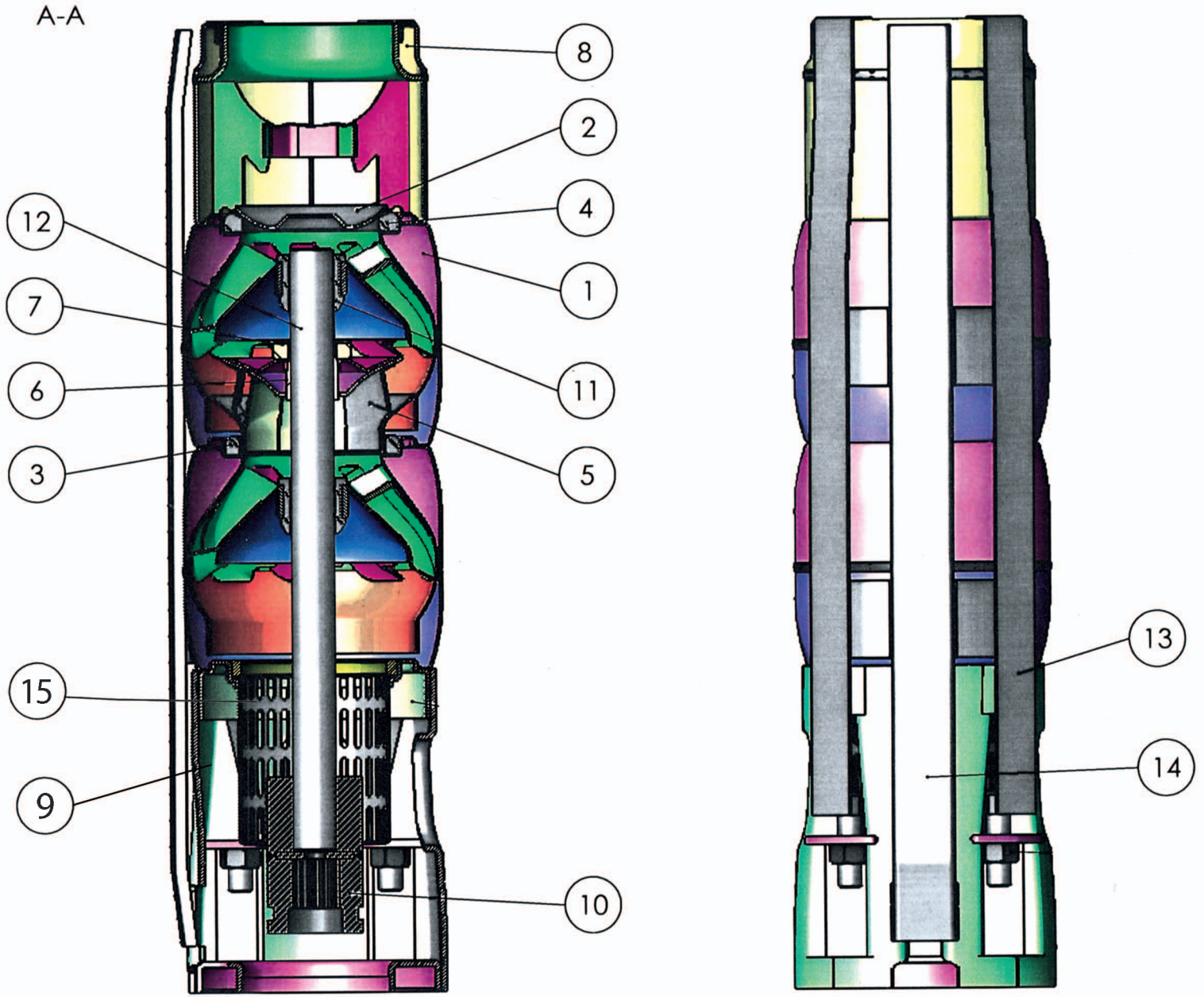

ITEM NO	PART NUMBER	MATERIAL	QTY
1	KADEME	AISI 304	1
2	KLAPE	AISI 304	1
3	BOYUN HALKASI	NİTRİL KAÜÇUK	2
4	KLAPE LASTİĞİ	NİTRİL KAÜÇUK	1
5	PERVANE	AISI 304	1
6	PENS	AISI 304	1
7	PENS SOMUNU	AISI 304	1
8	ÜST ÇIKIŞ	AISI 304	1
9	EMME KASASI	AISI 304	1
10	KAPLİN	NİTRİL KAÜÇUK	2
11	YATAK	NİTRİL KAÜÇUK	1
12	MİL	AISI 304	4
13	BİRLEŞTİRME	AISI 304	1
14	KABLO MUHAFAZASI	AISI 304	4
15	SÜZGEÇ	NİTRİL KAÜÇUK	2

ITEM NO	PART NUMBER	MATERIAL	QTY
1	STAGE	AISI 304	1
2	N.R.V FLAP	AISI 304	1
3	NECKRING	NİTRİL KAÜÇUK	2
4	FLAPRING	NİTRİL KAÜÇUK	1
5	IMPELLER	AISI 304	1
6	COLLATE	AISI 304	1
7	COLLATE NUT	AISI 304	1
8	N.R.V	AISI 304	1
9	SUCTION CASE	AISI 304	1
10	COUPLING	NİTRİL KAÜÇUK	2
11	BUSH	NİTRİL KAÜÇUK	1
12	SHAFT	AISI 304	4
13	CLAMPING	AISI 304	1
14	CABLE GUARD	AISI 304	4
15	STRANIER	NİTRİL KAÜÇUK	2

KURLAR

DALGIÇ POMPA SAN.TİC.LTD.ŞTİ.



İstiklal Mah.363. Sok. No:7 Kıraç / Esenyurt / İSTANBUL

Tel: +90(212) 886 75 95 - 96 - 97

Fax: +90(212) 886 66 89

www.kurlarpompa.com.tr

info@kurlarpompa.com.tr